

STEER AXLE MAINTENANCE

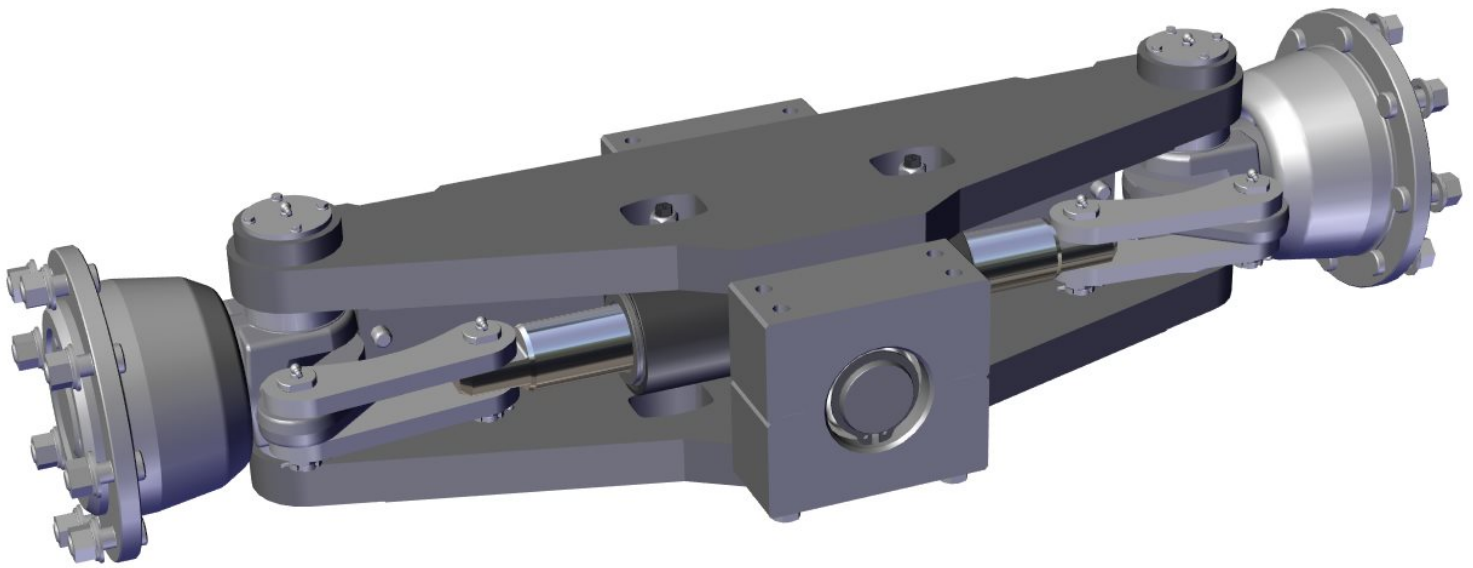

MAINTENACE INTERVALS

After 10 operating hours:

Check the nuts' tightening M22x1,5.(Tightening Torque is 640÷650 Nm).

Visual inspection; check if there are leakages from the cylinder.

After 400 - 500 operating hours:

Checking the tightening torques of all fasteners axle (see exploded view)

Enter grease again into all rolling and sliding parts.

Under normal conditions, bearings and ball joints must be greased once per year or after 400–500 functioning hours.

Inspect bearings and/or ball joints, Replace if damaged.

After each axle cleaning bearings must be greased again.

In case of use of the axle in dusty or in damp environment, Bearings and ball joints must be greased more times in a month; we recommend every 150-200 functioning hours.

Kind of grease: **GREASE HELIOLENE GREASE GRA 2 BLACK.**

Repeat this check each 400-500 functioning hours or 150-200 functioning hours (for dusty or in damp environment) in order to maintain the axle in perfect efficiency.

After 800 - 1000 functioning hours:

Verify the efficiency of bearings, ball joints and leakages from the cylinder.

Inspect bearings and/or ball joints, Replace if damaged.

Repeat this check each 800-1000 functioning hours in order to maintain the axle in perfect efficiency.

the axle is designed for use on flat pavement without obstacles.