

# **Ricco**

## **Transmission Service And Maintenance 15005110**

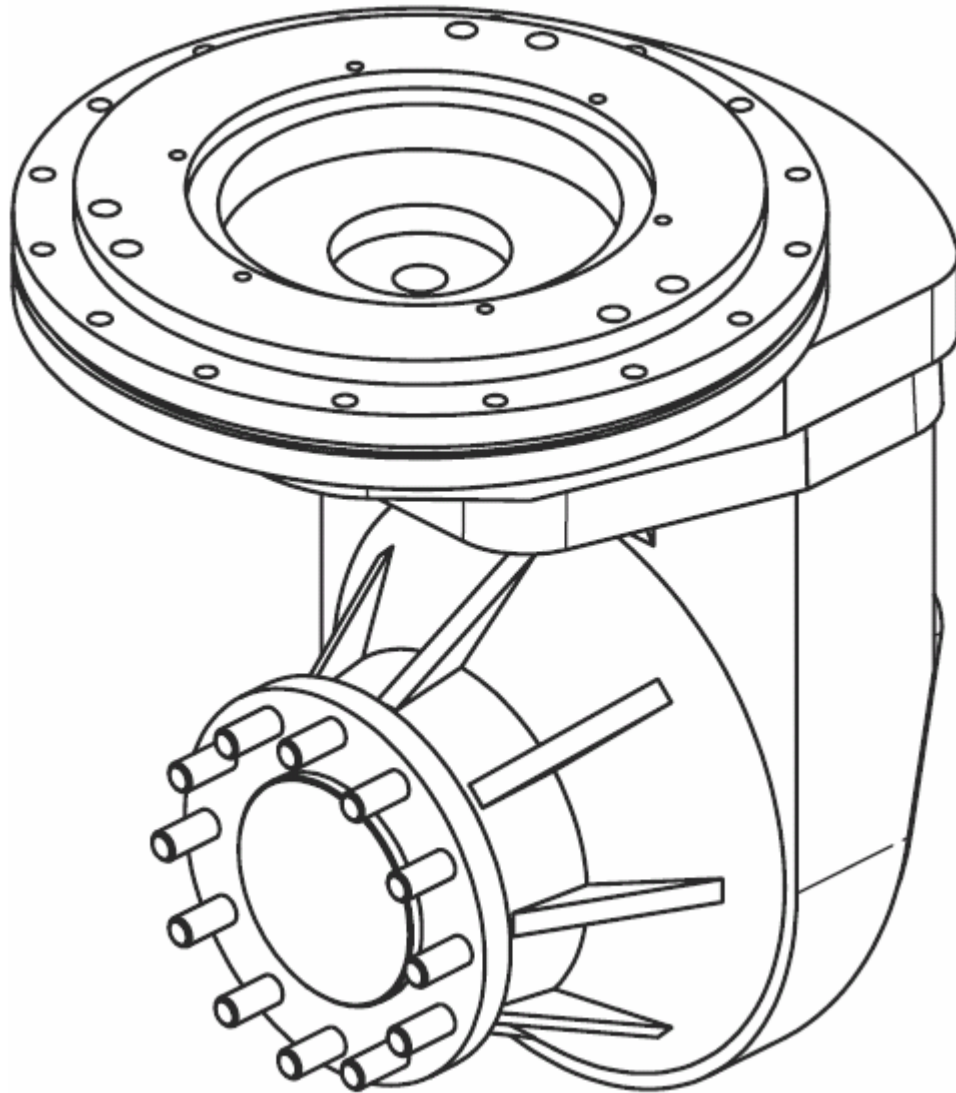

# Table of contents

---

Preface .....	3
Safety precautions .....	4
<b>I General remarks</b>	
1. Transmission components .....	5
2. Consumable stores .....	6
3. Standard tools and fixtures .....	7
4. Measuring tools .....	8
<b>II Special tools .....</b>	<b>9</b>
<b>III Disassembly</b>	
Preface .....	12
1. Draining the transmission oil .....	12
2. Removal and disassembly the upper part .....	13
3. Remove the transmission cover .....	14
4. Dismantle the crown gear and wheel shaft .....	14
5. Remove the taper roller bearing inner race from the wheel shaft and crown gear .....	15
5.1 Remove the taper roller bearing inner race from the wheel shaft .....	15
5.2 Remove the taper roller bearing inner race from the crown gear .....	15
6. Press out the wheel bolts from the wheel shaft .....	16
7. Dismantle the pinion shaft .....	17
7.1 Pull off the helical gear .....	17
7.2 Knock out the pinion shaft .....	17
7.3 Press the taper roller bearing outer race off the pinion shaft .....	17
8. Remove shaft seal .....	18
9. Remove the taper roller bearing outer race from the transmission housing .....	18
10. Remove the thread protective shield .....	18
<b>IV Assembly</b>	
Preface .....	19
1. Measure the assembly dimension of the pinion shaft .....	20
2. Pre-assembly of transmission housing .....	21
2.1 Bearing on pinion shaft .....	21
2.2 Bearing on wheel shaft .....	21
2.3 Mount the thread protective shield .....	21
2.4 Knock shaft seal into the housing .....	22
3. Pre-assembly of wheel shaft .....	22
3.1 Press in the wheel bolts .....	22
3.2 Mount the taper roller bearing inner race on wheel shaft .....	22
4. Mount the taper roller bearing inner race onto the crown gear .....	23
5. Mount the taper roller bearing inner race onto the pinion shaft .....	23
6. Mount the pinion shaft in the transmission housing .....	23
7. Measure the bearing clearance of the pinion shaft and adjust the prestress .....	24
7.1 Measure the bearing clearance .....	24
7.2 Mount the helical gear .....	25
7.3 Adjust the prestress on pinion shaft .....	25
8. Mount the wheel shaft and the crown gear to the housing .....	26
9. Measure the circumferential backlash on the crown gear and the bearing clearance on wheel shaft .....	26
9.1 Measure the circumferential backlash on the crown gear .....	26
9.2 Determine thickness of shims for bearing prestress .....	27
9.3 Adjustment of circumferential backlash and bearing prestress .....	27
10. Checking the tooth pattern .....	28
11. Mount the transmission cover .....	29

# Table of contents

---

12. Upper part assembly and mounting onto transmission .....	30
12.1 Mounting of trunnion bearing and supporting ring .....	30
12.2 Mount upper part onto transmission .....	31
12.3 Mount breather valve .....	31
V Adjusting data	
Adjusting data .....	32
Tightening torques .....	32
VI Function test .....	33
VII Storage / Commissioning	
1. Storage .....	34
2. Commissioning .....	34

# Preface

---

**This manual concerns the adequate repair of the HFK 600 transmission series.**

We recommend to read this manual completely before starting with repairs, as some of works described are rather complex.

Along with standard tools, some special tools are required to do the repair work.  
It is strongly recommended to use them.  
These special tools can be acquired from RICO.

The present manual is based on the state of the art at the time of printing.  
We have done our utmost to avoid any errors in this manual. We cannot be made liable, however, for any misrepresentations, wrong descriptions or omissions.  
There may also be modifications due to technical advancements.

We reserve the right to introduce modifications without prior announcement.

The removal and installation as well as the repair of accessories are not dealt with here. Please refer to the relative manuals.

Important information related to technical reliability and operational safety are highlighted by the identifying signs as follows:



**Note**

Applies to instructions to which particular attention requires to be given when performing the work.



**Attention**

Relates to job and operating procedures which require to be strictly adhered to avoid any damage or destruction of parts



**Warning**

Relates to job and operating procedures which require to be strictly adhered to eliminate any possible risk to persons.

# Safety precautions

---

The following safety precautions should be observed in particular:

- **The helical-bevel gear transmission of the HFK series has been designed according to the most recent state of the art and can be operated safely. However, if it is used by untrained personnel or not according to its purpose, its operating will be dangerous.**
- **Its purposeful use also comprises the heeding of the manufacturer's instructions for installation, assembly and disassembly, commissioning and maintenance.**
- **Every person concerned with installation, assembly and disassembly, commissioning and maintenance of the transmission at the works of the user must have read and understood the complete Manual, and specifically the Safety Precautions.**
- **It should be refrained from every activity affecting the operating safety of the transmission.**
- **Unauthorized conversions and modifications might influence the operating safety of the transmission and are not permitted.**

**The work described may only be carried out by authorized, trained and briefed personnel.**

- **Detergents must not come into contact with the skin, nor must they be swallowed or their vapours be inhaled. Use protective gloves and glasses. If detergent has been swallowed, call the doctor immediately. Manufacturer's instructions should also be observed.**
- **Do not drain detergents and transmission oil into sewage system.**
- **Block the wheels before starting any work, whether it is mounted or built in.**
- **Before starting any work on the built-in transmission (such as, oil change), it is necessary on principle to disconnect or switch off the voltage supplies for the motor.**
- **Before removing the drive unit, the non-driven wheels of the vehicle should be blocked by means of wedges and the vehicle be supported against tilting with adequate means. Please observe the safety remarks and instructions of the vehicle manufacturer.**
- **The local safety and accident prevention rules should be observed.**

# I General remarks

## 1. Transmission components

The helical bevel gear transmission of the HFK series comprises essentially the following subassemblies and components:

- ⇒ Transmission housing           item 1
- ⇒ Wheel shaft                    item 2
- ⇒ Gear set, consisting of:
  - Pinion shaft                    item 3
  - Crown gear                    item 4
  - Motor pinion and helical gear   not illustrated
- ⇒ Upper part                    item 5
- ⇒ Trunnion bearing            item 6
- ⇒ Transmission cover          item 7
- ⇒ Thread protective shield    item 8

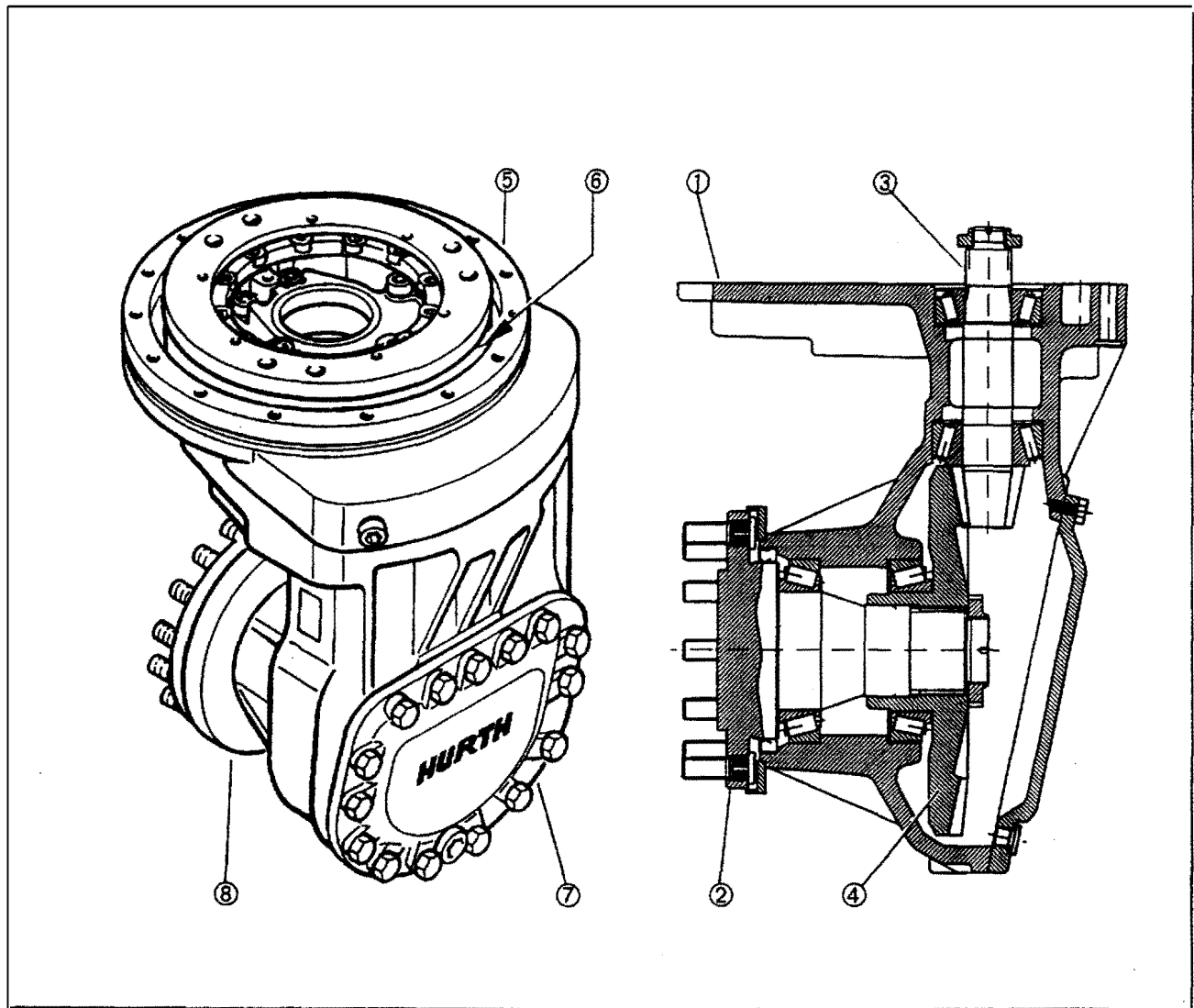

Figure I-1

# I General remarks

---

## 2. Consumable stores

### for cleaning

Cold cleaners, such as, petroleum ether or LOCTITE fast cleaner No. 706.



**Detergents may not come into contact with the skin, they must not be swallowed and their vapours must not be inhaled. Always use protective gloves and goggles. In case of skin contact, wash immediately with plenty of water! If a detergent has been swallowed inadvertently, call medical help immediately. Pertinent instructions of the manufacturer should be duly noted.**

### for assembly

LOCTITE no. 242      for securing screws, medium-hard  
LOCTITE no. 270      for securing spline connections  
LOCTITE no. 574      surface seal

◁ for checking the tooth pattern

Transmission fluid according to API GL 4 or MIL L 2105.

Viscosity classes:

#### Standard fluid:

Ambient temperature:                      0-40 °C    SAE 80-90

#### Deep temperature fluid:

Ambient temperature:                      down to -26 °C    SAE 80W

Ambient temperature:                      down to -40 °C    SAE 75W



For special applications or if the transmission is to be used with synthetic fluid, RICO should be contacted beforehand.

### Required fluid quantity: approx. 7 liters

The amounts of fluid indicated are standard values. The correct fluid level has been reached when the fluid is at the lower edge of the fluid filling opening (overflow).

# I General remarks

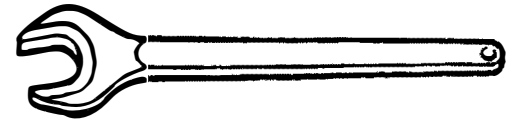
## 3. Standard tools and fixtures

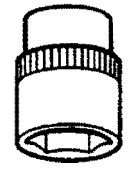
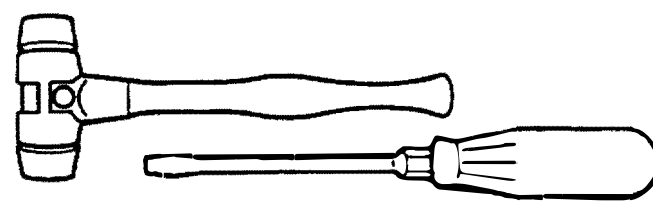
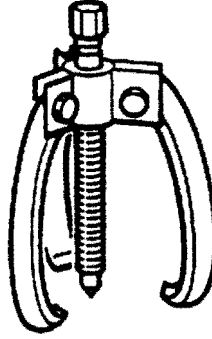
Wrench	13 mm 17 mm 19 mm	
Allen key	6 mm 8 mm 10 mm	
Torque wrench adjustable to 350 Nm		
Hexagon socket wrench	13 mm 17 mm 19 mm 41 mm	
Plastic hammer Steel hammer sturdy screwdriver or tire lever	1000g 250g	
Three-arm or two-arm extractor		



# I General remarks

## 4. Measuring tools

Dial gauge with magnet

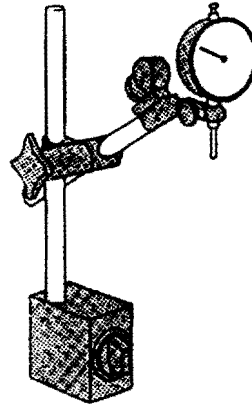

Micrometer depth gauge  
measuring depth up to 70 mm

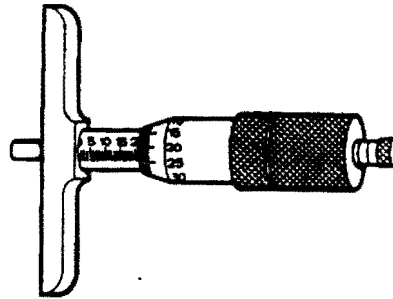

Micrometer depth gauge with dial gauge

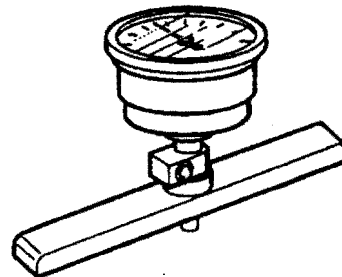

Micrometer  
Measuring range from 0 to 25 mm  
Accuracy of reading 1/100 mm (.0004 in.)

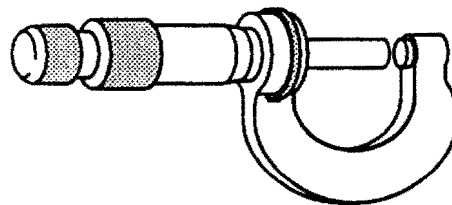

Measuring tool  
Measuring the mounting dimension of pinion shaft

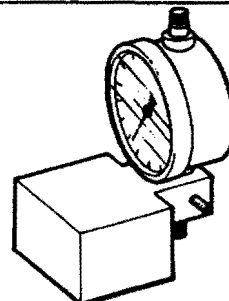

## II Special tools

"A" **Mounting plate** Ident no.

if no swivelling stand is available

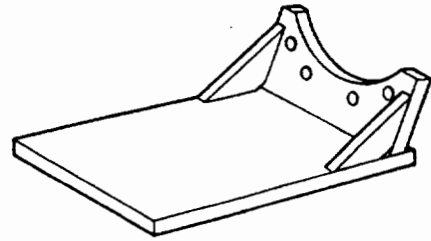

"B" **Bush** Ident no.

Disassembly the taper roller bearing inner race from the pinion shaft

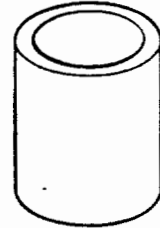

"C" **Bush** Ident no.

Mounting the taper roller bearing inner race on the pinion shaft

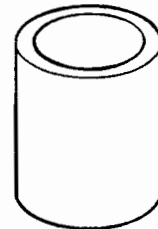

"D" **Measuring bush** Ident no.

For measuring the mounting dimension of the pinion shaft

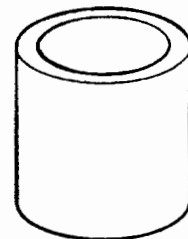

"F" **Clamping device** Ident no. 618 727

For clamping the pinion shaft into the transmission housing







"G" **Bush** Ident no.

Mounting the taper roller bearing inner race on the pinion shaft

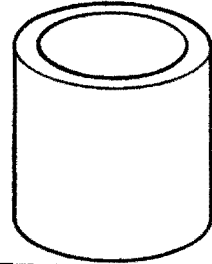

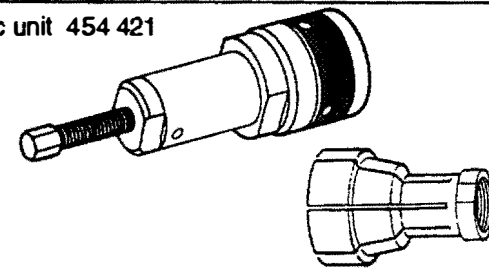
## II Special tools

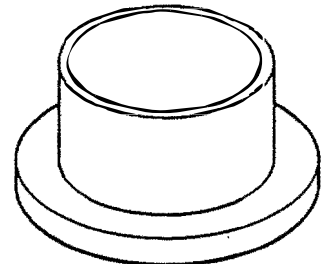
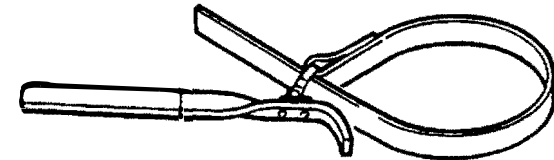
<b>"H"</b>	<b>Bush</b> Mounting the taper roller bearing inner race on the wheel shaft and the crown gear	Ident no.	
<b>"L"</b>	<b>Socket wrench</b> Disassembly and assembly the tightening nut for the wheel shaft tightening	Ident no.	
<b>"M"</b>	<b>Extractor</b> Pull off taper roller bearing inner race on wheel shaft and crown gear	Ident no. Basic unit 454 421	
<b>"N"</b>	<b>Disk</b> Pull off taper roller bearing inner race on crown gear	Ident no.	
<b>"O"</b>	<b>Bush with collar</b> Disassembly and assembly of wheel bolts	Ident no.	
<b>"P"</b>	<b>Strap wrench</b> Seize helical gear while disassembly and assembly		

## II Special tools

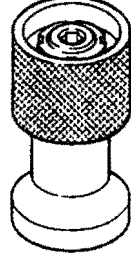
<b>"Q"</b> <b>Bearing adjustment unit</b> for checking the bearing clearance and adjusting the prestress	Ident no.	
--	-----------	---

<b>"S"</b> <b>Mandrel</b> for driving the venting filter in	Ident no.	
--	-----------	--

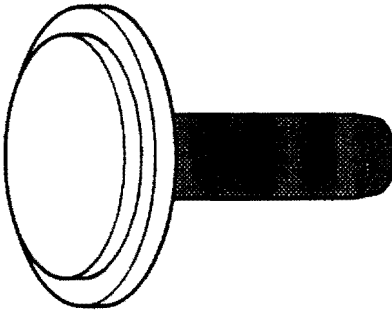
<b>"T"</b> <b>Mandrel</b> for driving the shaft seal in	Ident no.	
--	-----------	---

# III Disassembly

## Preface

Clean the transmission thoroughly on the outside before disassembling

A well-lit and clear working place, which is free from dirt and swarf chips, will assist the work.

All necessary working steps are constantly described and illustrated.

Parts which can only be replaced by subassemblies are not to be disassembled further.

For disassembling the drive unit from the vehicle, the instructions issued by the vehicle manufacturer must be strictly observed.

We recommend to use a swivelling stand for disassembling and assembling

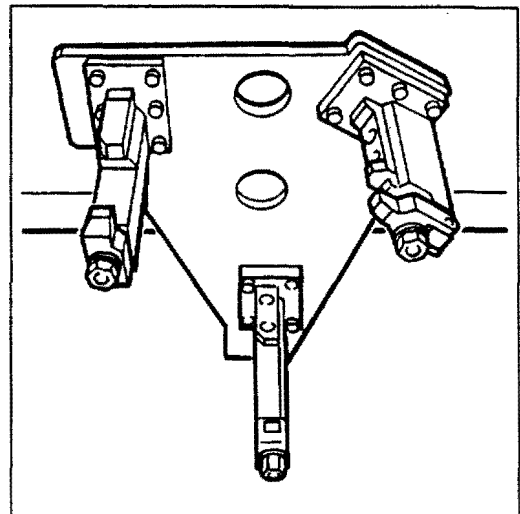

Swivelling stand

### .. Draining the transmission oil

Place a suitable vessel under the drain plug and unscrew the oil drain plug using an Allen wrench 6 mm.

Collect the transmission oil completely in the vessel.

Figure III1-1



Do not drain the oil on the soil nor into the sewage system.

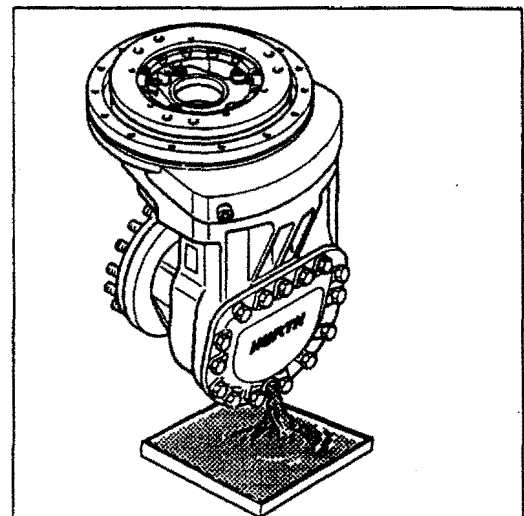

Figure III1-1

# III Disassembly

## 2. Removal and disassembly the upper part



Disassemble the upper part only in case the trunnion bearing must be exchanged.

Remove centering ring (item 2).

Unscrew supporting ring (item 3) and remove.

Unscrew two socket head screws (item 4) and hexagon nuts (item 5).

Unscrew two socket head screws (item 6).

Turn transmission and remove all hexagon head screws (item 7).

Knock slightly from below against the upper part with a plastic hammer to disengage it from the transmission housing. Remove the transmission upper part carefully.



Remove pin (item 8) and breather valve (item 9) only when damaged.

Figure III2-3

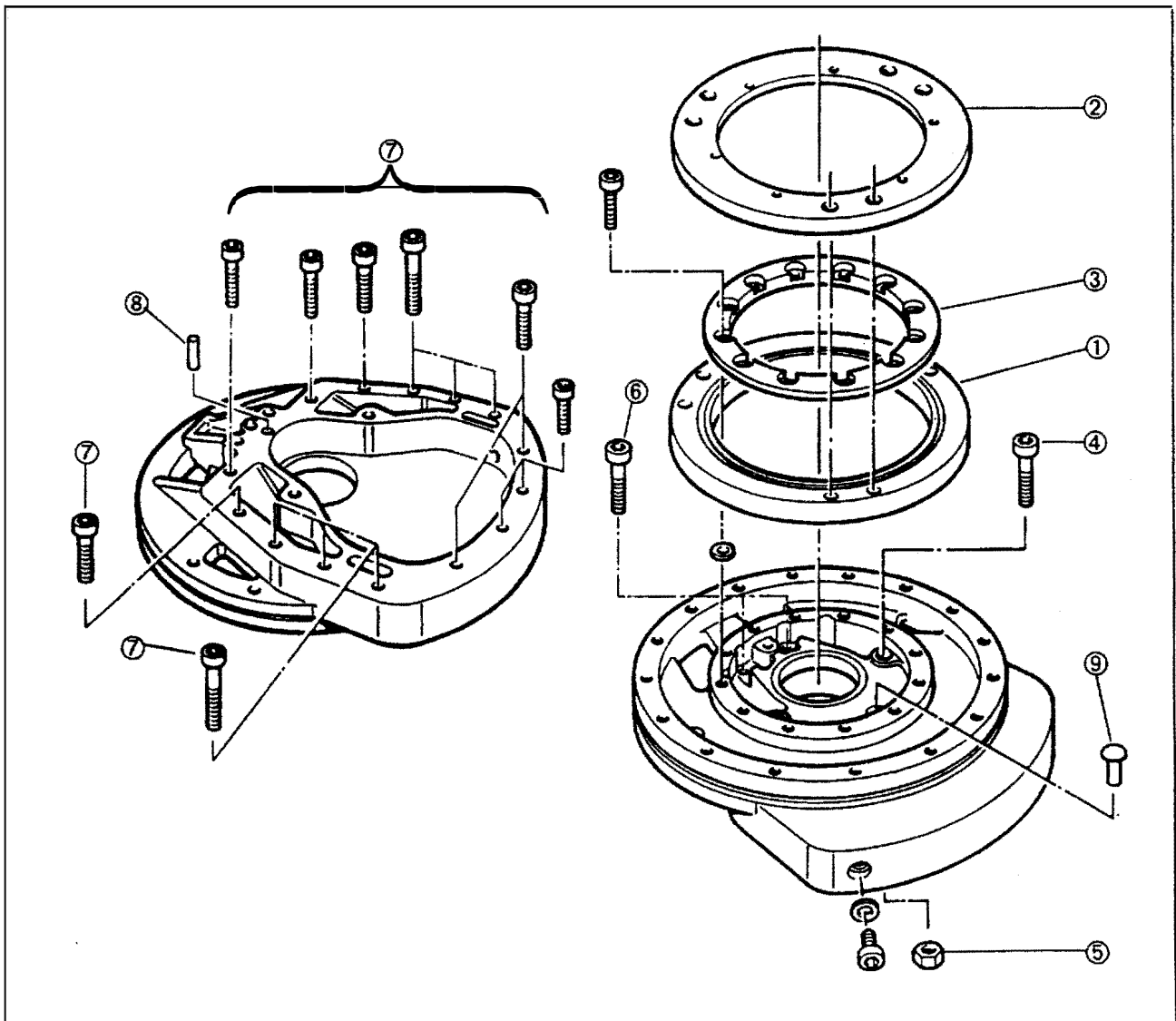

Figure III2-3

# III Disassembly

## 3. Remove the transmission cover

Unscrew hexagon screws (item 1).

Loosen transmission cover (item 2) by knocking slightly with a plastic hammer and lift it off.

Figure III3-1

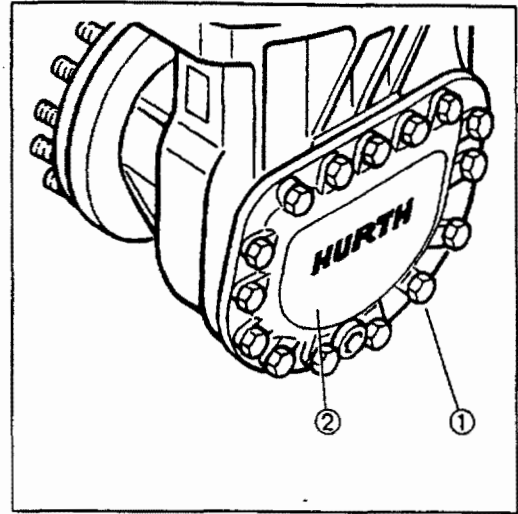

Figure III3-1

## 4. Dismantle the crown gear and wheel shaft

Place the transmission in the swivelling stand and tighten.

Screw 2 wheel nuts onto the wheel bolts and block the wheel shaft with a lever.

Unscrew grooved nut with socket wrench "L" and remove shims from the wheel shaft.

Figure III4-1

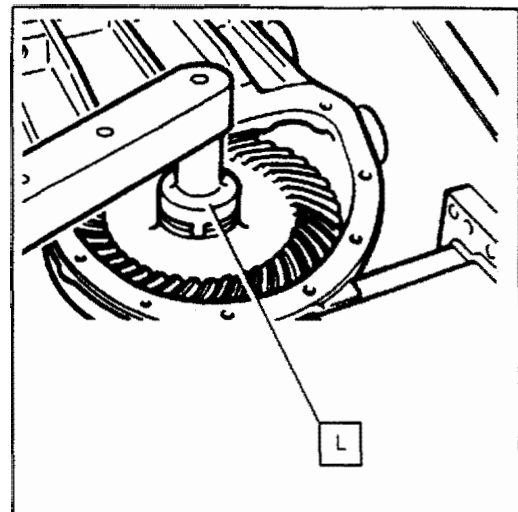

Figure III4-1

Drive the wheel shaft (item 1) out of the housing, using a copper mandrel and a hammer.

Figure III4-2



The crown gear is fitted to the wheel shaft with LOCTITE 270. By heating the crown gear to 100 to 120 °C ( 212 to 248 °F) by means of the flame of a welding torch, the wheel shaft can be more easily driven out.



**Aggressive vapours may be generated by heating the remains of LOCTITE. Ventilate the room well and wear a protective mask if necessary! Remove heated crown gear only with protective gloves!**

When dismantling the wheel shaft, the radial shaft sealing ring (item 2) may be damaged and should be replaced in any case.

Take the crown gear (item 3) carefully out of the housing

Figure III4-2

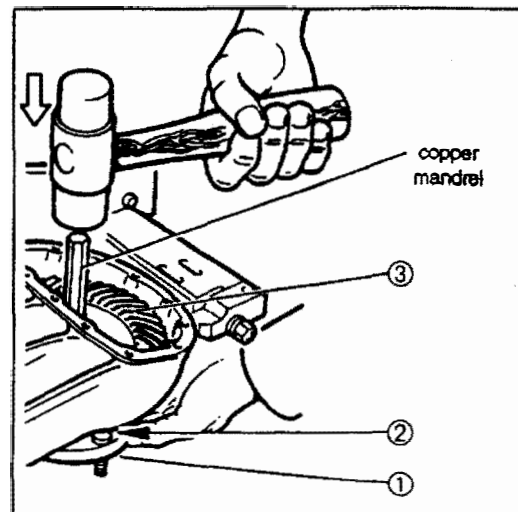

Figure III4-2

### III Disassembly

#### 5. Remove the taper roller bearing inner race from the wheel shaft and crown gear

If the taper roller bearings are to be reused, we recommend to employ the extractor unit "M".

#### 5.1 Remove the taper roller bearing inner race from the wheel shaft

Place collet of the extractor onto the rollers.  
Tighten collet to rollers by means of cap nut  
Screw spindle against shaft and pull bearing inner race (item 1) evenly and carefully from the wheel shaft (item 2).  
Figure III5-1

#### 5.2 Remove the taper roller bearing inner race from the crown gear

When pulling the bearing inner race (item 3) off the crown gear (item 4), proceed as described above.  
Clamp the crown gear on a fitter's bench and insert the disk "N" for supporting the spindle into the crown gear bore.  
Figure III5-1

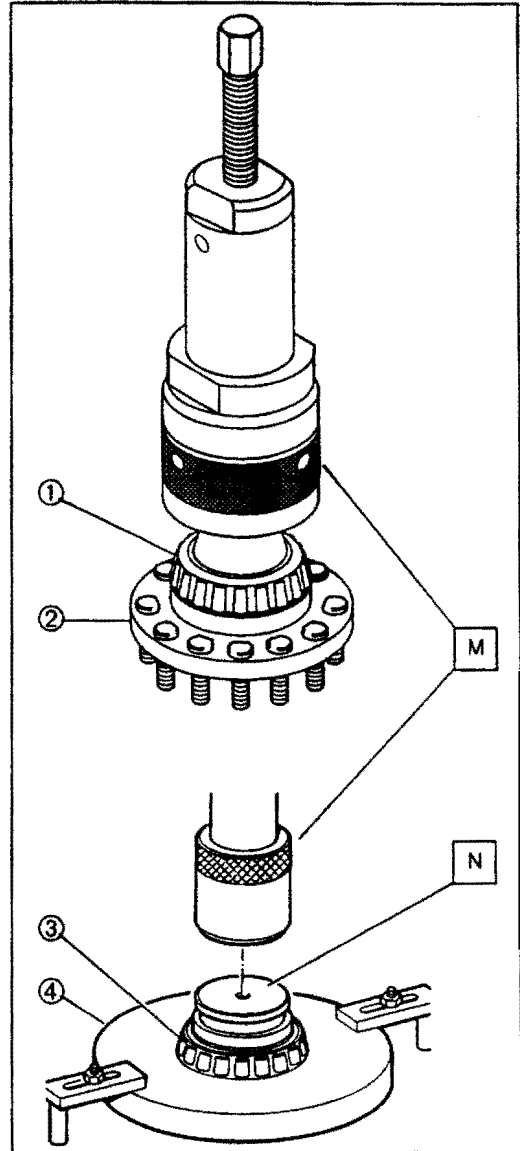

Figure III5-1

If the taper roller bearings are to be renewed:

Cut bearing cage (item 1) open and remove rollers (item 2).  
Pull the bearing inner race carefully off by means of an extractor (e.g. a three-arm extractor) over the small bearing collar ( $\Rightarrow$ ).  
Figure III5-2

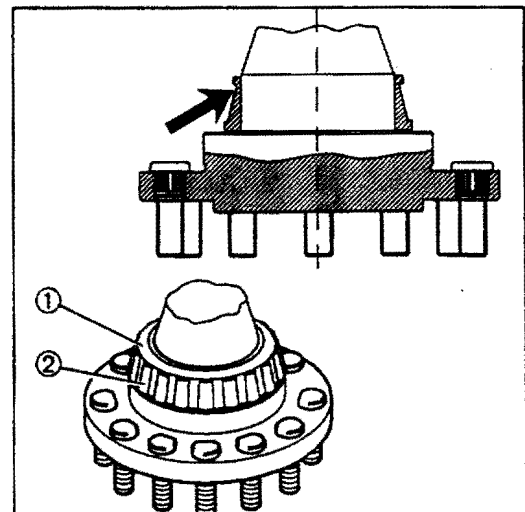

Figure III5-2



### III Disassembly

---

#### 6. Press out the wheel bolts from the wheel shaft

The wheel bolts (item 1) can only be pressed out when the wheel shaft (item 2) has been removed from the transmission.

Place the wheel shaft into the special tool "O" and press out the wheel bolts.

Figure III6-1

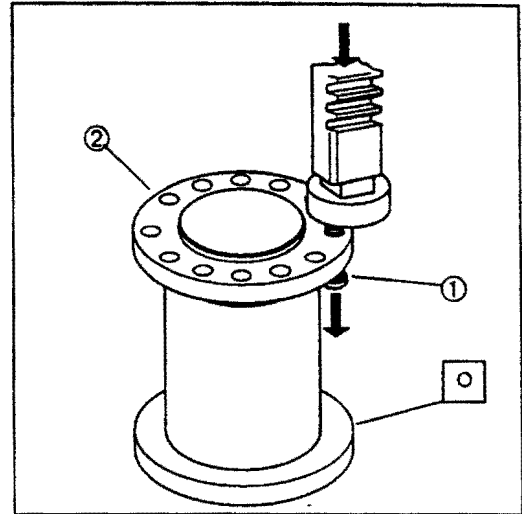

Figure III6-1

# III Disassembly

## 7. Removal of the pinion shaft

### 7.1 Pull off the helical gear

The pinion shaft can only be dismantled after having removed the crown gear first.

Unscrew hexagon nut (item 1).  
Hold the helical gear tight using the strap wrench "P".

Pull the helical gear (item 2) off the pinion shaft (item 3) by means of an extractor.

Figure III7-1



The helical gear is fitted to the pinion shaft with LOCTITE 270. By heating the helical gear to approx. 100 to 120 °C (212 to 248 °F) by means of a welding torch flame, the helical gear can be pulled off easier.



**Aggressive vapours may be generated by heating the remains of LOCTITE. Ventilate the room well and wear a protective mask if necessary! Remove heated crown gear only with protective gloves!**

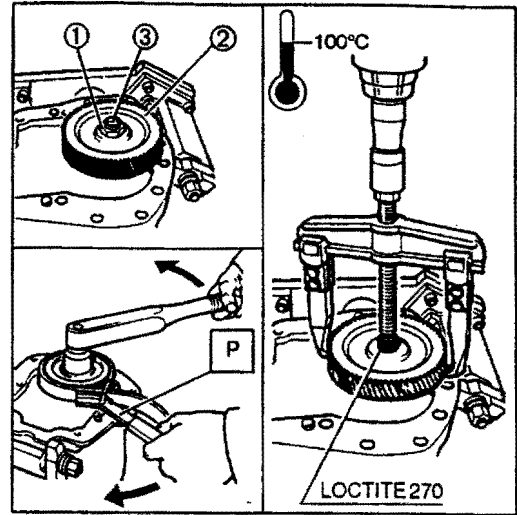

Figure III7-1

### 7.2 Knock out the pinion shaft

Knock out the pinion shaft (item 1) using a plastic hammer  
Figure III7-2



**When knocking the shaft out, it must not be damaged.**

Take the taper roller bearing inner race (item 2) out of the housing (item 3).  
Figure III7-2

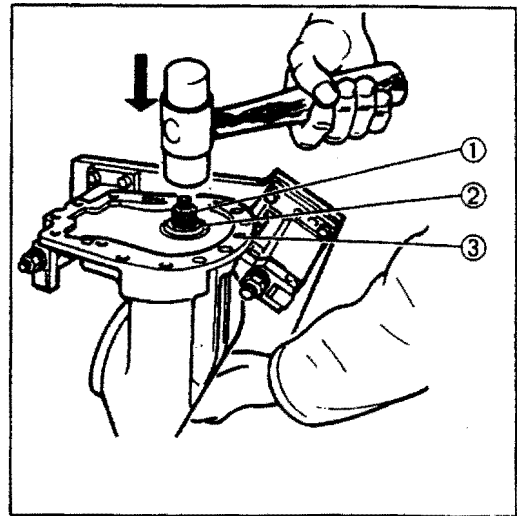

Figure III7-2

### 7.3 Press the taper roller bearing outer race off the pinion shaft

Push the taper roller bearing inner race (item 1) off the pinion shaft (item 2) using the bush "B".

Figure III7-3

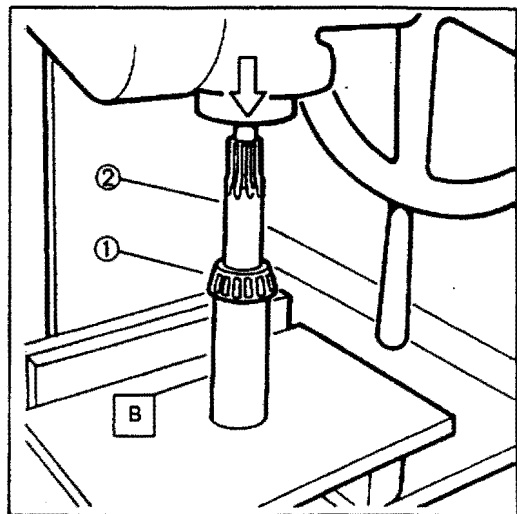

Figure III7-3

# III Disassembly

## 8. Removal of shaft seal

Prior to the replacement of the shaft seal the wheel shaft has to be removed.  
Removal of wheel shaft refer to chapter 4.

Knock out the shaft seal (item 1) with a mandrel and a hammer.  
Figure III8-1

## 9. Remove the taper roller bearing outer race from the transmission housing

Drive the bearing outer races (items 2-5) for supporting the wheel and pinion shafts carefully out of the housing by means of a copper mandrel and a hammer.

When driving the outer races out, make sure not to damage the shims (items 6-8).  
Figure III8-1



Place the outer races and the shims always close to the relative bearing inner races. Do not re-use distorted or damaged shims.

## 10. Remove the thread protective shield

Remove the thread protective shield only in case it is damaged.  
Knock off the shield carefully with a hammer.  
Figure III8-1

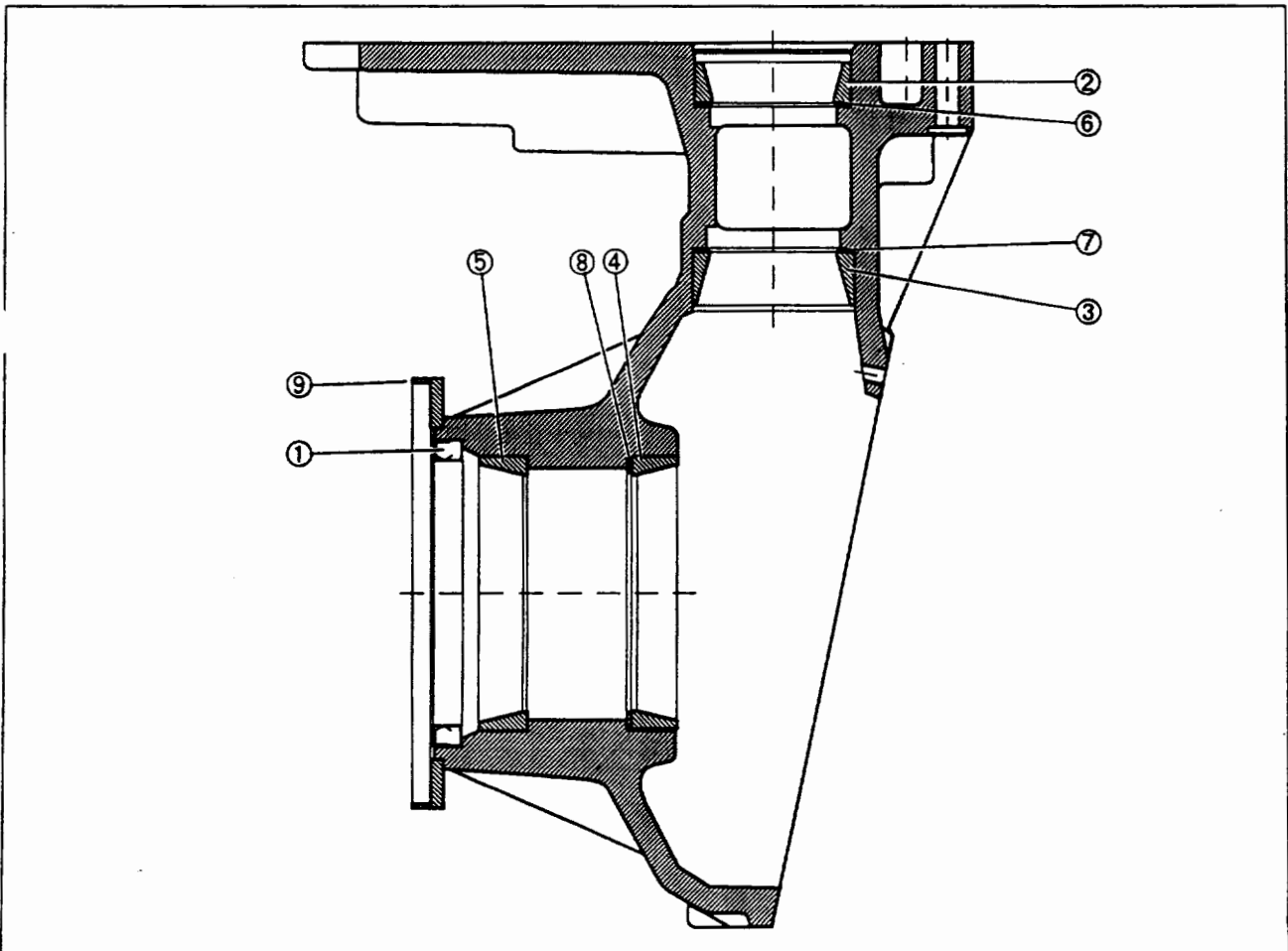

Figure III8-1

# IV Assembly

---

## Preface

Clean all components thoroughly and remove all remainders of LOCTITE.



**Detergents must not come into contact with the skin, nor must they be swallowed or their vapours be inhaled. Use protective gloves and glasses. If detergent has been swallowed, call the doctor immediately. Manufacturer's instructions should also be observed.**

Check all parts for wear, damage and cracks and replace parts if required.

In case of damaged gears exchange in sets only.

New gear sets require new taper roller bearings.

If taper roller bearings are damaged, replace always completely (inner and outer races).  
Do not re-use distorted or damaged shims.

Smooth sealing faces with an oil stone or a fine finishing file.

**The following new parts are required for assembly:**

- Shaft seal for wheel shaft sealing
- Grooved nut for securing the wheel shaft
- Hexagon nut for securing the cylindrical gear
- Shims for adjustment of bearings and backlash
- Sealing ring at the oil drain and oil filling plugs

## IV Assembly

### 1. Measure the assembly dimension of the pinion shaft

Insert measuring bush "D" into bearing borehole of the housing and measure dimension F.

The housing dimension E is determined according the following formula:

$$E = L - F + d/2$$

L = Length of measuring bush "D" (marked)

F = Dimension from bearing seat diameter to end face of measuring bush "D"

borehole diameter  $d = 125^{P7}$  mm (124.972 - 124.932 mm) (4.92016 - 4.91858 in.)

$d/2 = 62.486 - 62.466$  mm (2.46008 - 2.45929 in.)

The thickness X of the shims (item 1) is calculated according to the following formula:

$$X = E - B - T$$

F = Housing dimension

= Assembly dimension of pinion shaft (marked)

T = Bearing width (item 2)

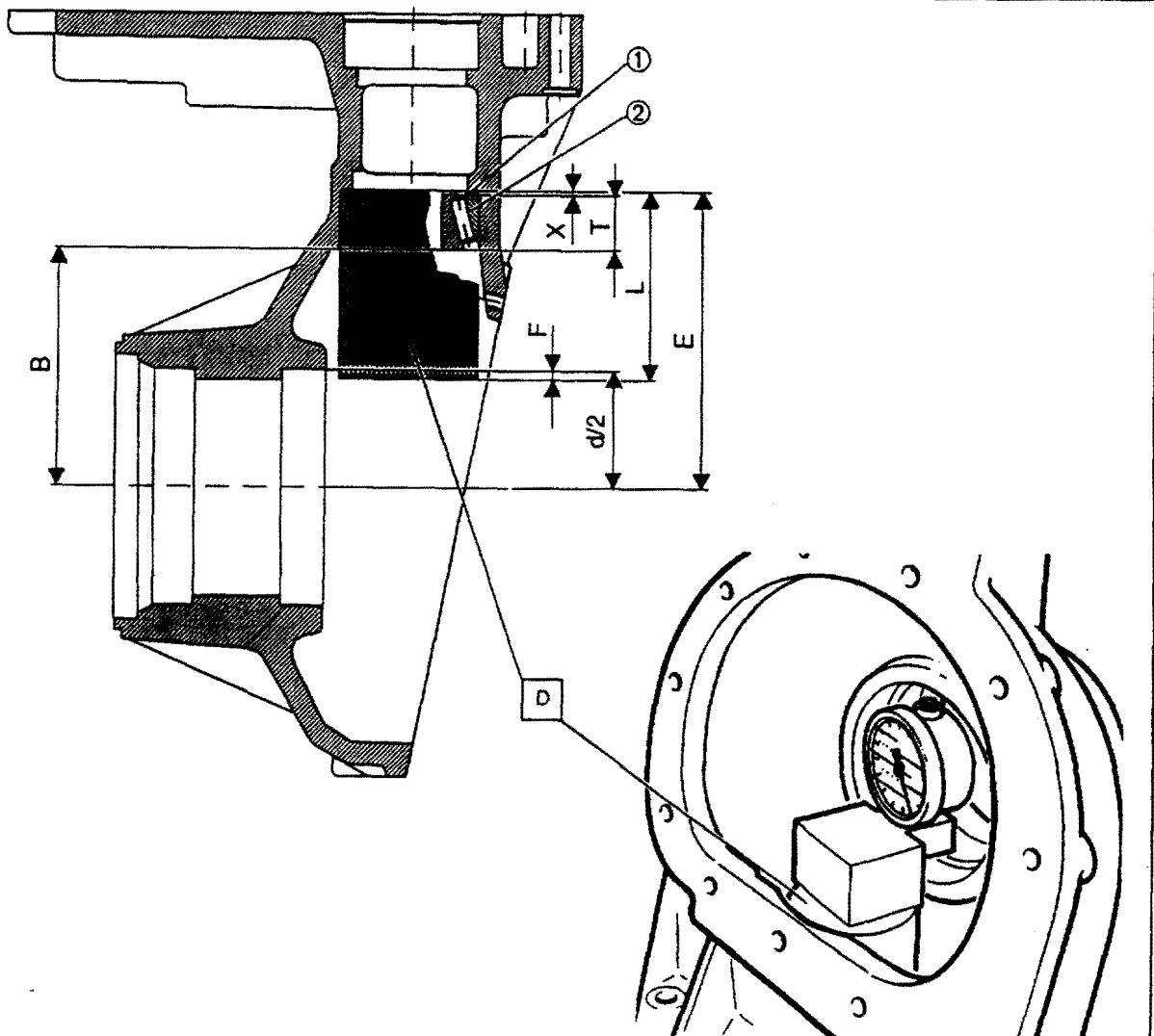

Figure IV1-1

# IV Assembly

## 2. Pre-assembly of transmission housing

### 2.1 Bearing on pinion shaft

Obtain the thickness of shims determined in Section 1 by means of shims of different thicknesses.

Insert shims (item 1) into the seat of the bearing.

Drive the bearing outer race (item 2) into the bearing seat in the housing.

Figure IV2-1



Plus 0.05 mm ( 0.002 in.) and minus 0.05 mm (0.002 in.) deviation from the measured value is admissible.

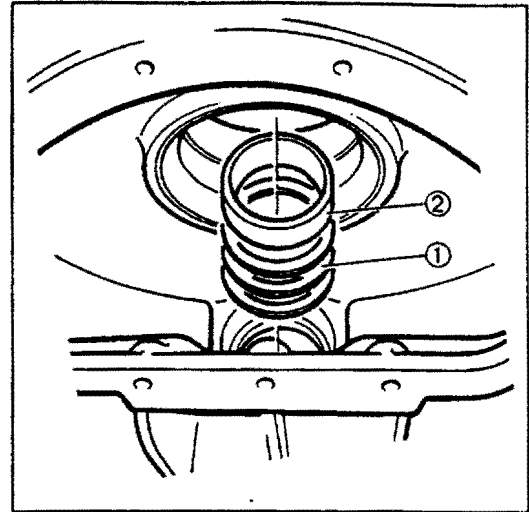

Figure IV2-1

### 2.2 Bearing on wheel shaft

Drive the bearing outer race (item 1) into the bearing seat in the housing with a copper mandrel.

Figure IV2-2

Insert the package of shims (item 2) (removed at disassembly) into the second bearing seat for preliminary adjustment.

Press the bearing outer race (item 3) into the bearing seat.

Figure IV2-2

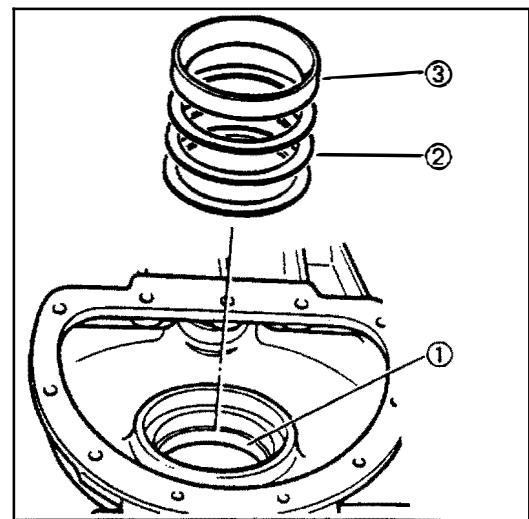

Figure IV2-2

### 2.3 Mount the thread protective shield

Clean seat on the housing thoroughly.

Heat thread protective shield (item 1) to approx. 80°C (176°F) in an oven and mount it on to the seat.

Figure IV2-3



Use protective gloves!

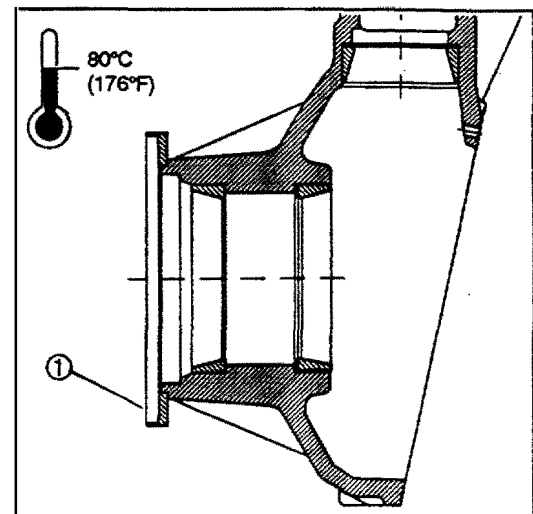

Figure IV2-3

# IV Assembly

## 2.4 Knock shaft seal into the housing

Knock shaft seal carefully into the housing up to the stop with tool "T". Open side of the seal must point into the housing. Figure IV2-4

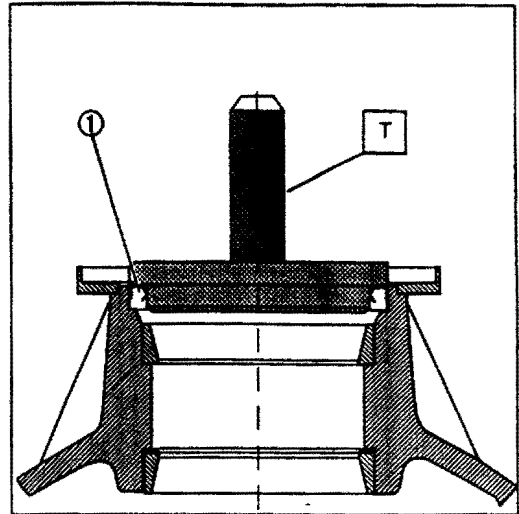

Figure IV2-4

## 3. Pre-assembly of wheel shaft

### 3.1 Press in the wheel bolts

Press the wheel bolt (item 1) using bush "O" into the wheel shaft up to the stop. Figure IV3-1



When pressing the bolt in, make sure that the flattened side on the bolt collar ( $\Rightarrow$ ) is directed towards the wheel shaft center.

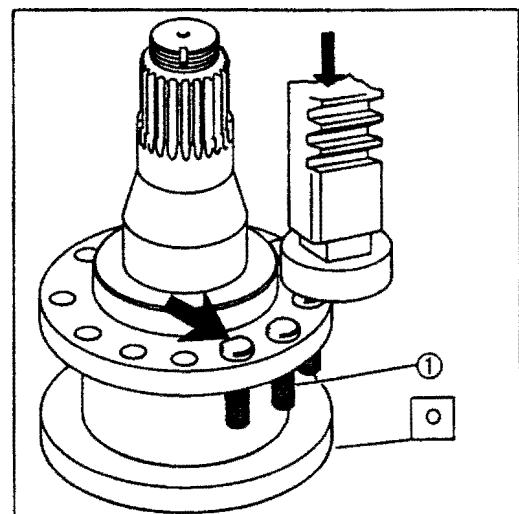

Figure IV3-1

### 3.2 Mount the taper roller bearing inner race on wheel shaft

Insert wheel shaft on bush "O".

Press taper roller bearing inner race (item 1) carefully onto the wheel shaft (item 2) up to the stop using bush "H". Lubricate the taper rollers with transmission oil.

Figure IV3-2

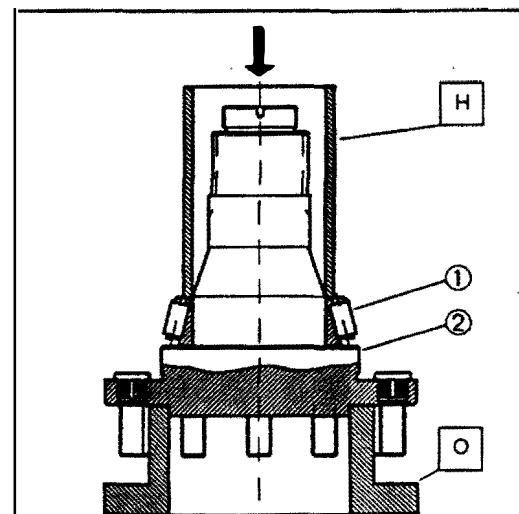

Figure IV3-2

## IV Assembly

### 4. Mount the taper roller bearing inner race onto the crown gear

Press taper roller bearing inner race (item 1) carefully onto the crown gear (item 2) up to the stop using bush "H". Lubricate the taper rollers with transmission oil.

Figure IV4-1

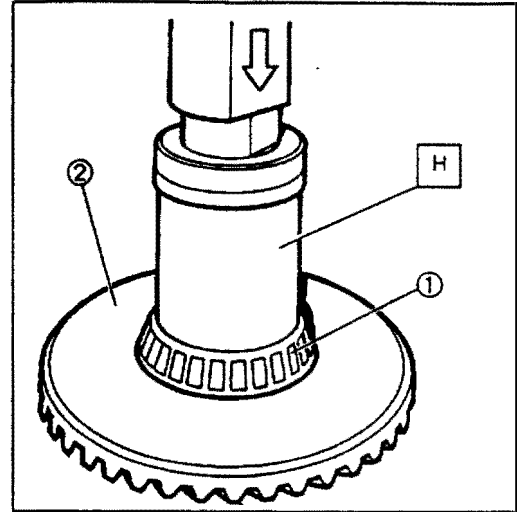

Figure IV4-1

### 5. Mount the taper roller bearing inner race onto the pinion shaft

Press taper roller bearing inner race (item 1) carefully up to the stop using bush "C". Lubricate the taper rollers with transmission oil.

Figure IV5-1

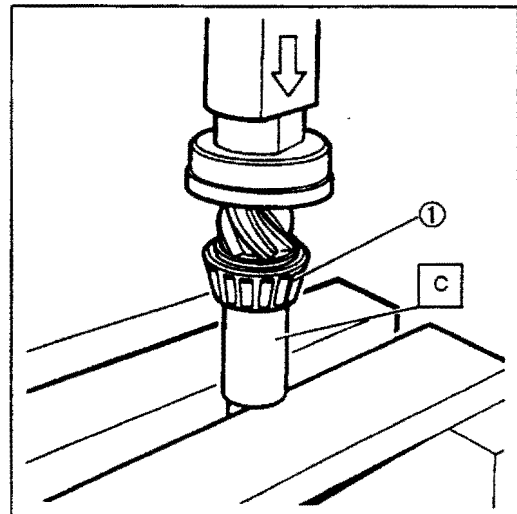

Figure IV5-1

### 6. Mount the pinion shaft in the transmission housing

Lubricate the taper rollers with transmission oil.

Insert the previously mounted pinion shaft from below into the housing and preload it slightly against the bearing outer ring in the housing by means of clamping device "F".

Figure IV6-1

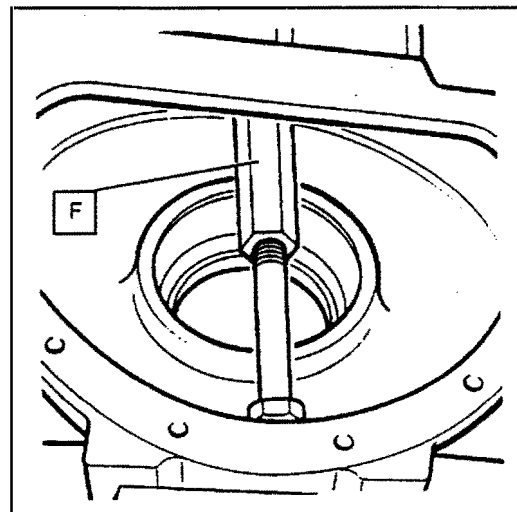

Figure IV6-1



# IV Assembly

## 7. Measure the bearing clearance of the pinion shaft and adjust the prestress

### 7.1 Measure the bearing clearance

The thickness of the shims to be fitted can be determined on the basis of the following dimensions:

Dimension C = Measure the distance between the collar of the pinion shaft and the limit stop of the bearing outer race.

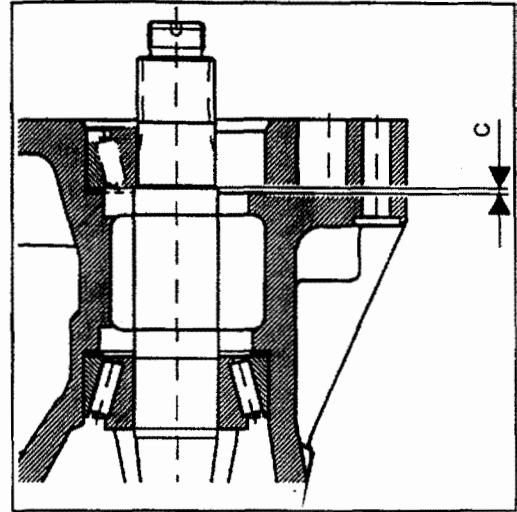

Figure IV7-1

Dimension S = Measure the distance between the plane surface of the bearing outer race and the plane surface of the bearing inner race.

If the outer race is lower than the inner race (dimension S, see Fig. IV7-2), dimension X (thickness of shims) is determined as follows:

Thickness of shims  $X = C + S - 0.1 \text{ mm (0.004 in.)}$

If the outer race is higher than the inner race (dimension S, see Fig. IV7-2), dimension X (thickness of shims) is determined as follows:

Thickness of shims  $X = C - S - 0.1 \text{ mm (0.004 in.)}$

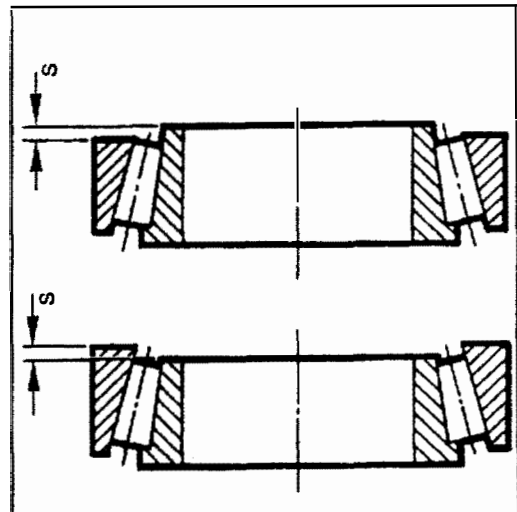

Figure IV7-2

Insert package of shims (item 1) into the housing.

Figure IV7-3

Press taper roller bearing outer race (item 2) into the housing.

Press taper roller bearing inner race (item 3) carefully onto the pinion shaft up to the stop using bush "G".

Figure IV7-3

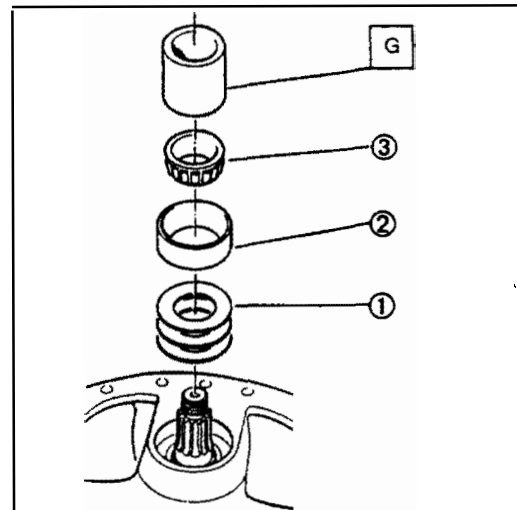

Figure IV7-3

# IV Assembly

## 7.2 Mount the helical gear

Place the helical gear (item 1) onto the pinion shaft (item 2) and screw on the new hexagon nut (item 3).

Figure IV7-4

Hold the helical gear tight using the strap wrench "P".  
Tightening torque: 60 Nm (44 ft-lb)



After adjusting the prestress and checking the tooth pattern, the hexagon nut is locked by caulking

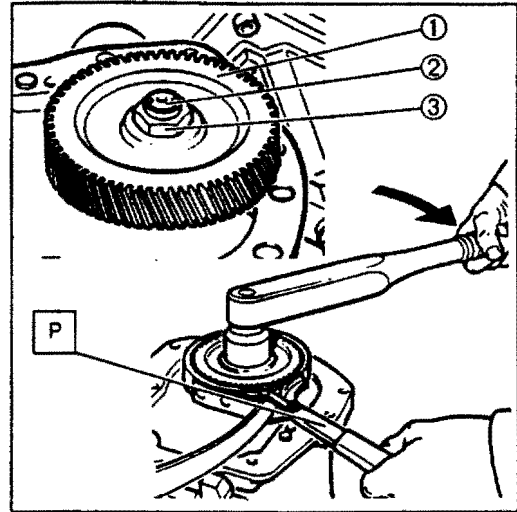

Figure IV7-4

## 7.3 Adjust the prestress on pinion shaft

Remove clamping device "F" (see figure IV6-1).

Press the pinion shaft downwards by hand and turn it for several times to align the rollers in the taper roller bearing

Place dial gauge according to Figure IV7-5 and turn dial face to zero position.  
Mark the measuring point on the helical gear with a coloured pencil.

Lift pinion shaft carefully, using two screwdrivers or two tire levers. Read the values displayed by dial gauge.



This step should be done very carefully to obtain the actual bearing clearance.

Press pinion shaft downwards by hand and spin it several times. Then repeat measuring procedure. The value measured must be reproduceable.

**Prestress of taper roller bearing:**

0.02 - 0.07 mm (0.0008 - 0.0028 in.)

The measured play plus 0.07 mm (0.0028 in.) establish the thickness of the shims.



Aspire to a bearing prestress of 0.07 mm (0.0028 in.). Round off the determined thickness of shims to 0.05 mm (0.002 in.)

Remove helical gear and pinion shaft. Insert the corresponding shims.

Coat splines of the helical gear with LOCTITE 270. Mount pinion shaft and helical gear again.

Tightening torque of the hexagon nut: 200 Nm (148 ft-lb)



Wipe excessive LOCTITE off with a rag.

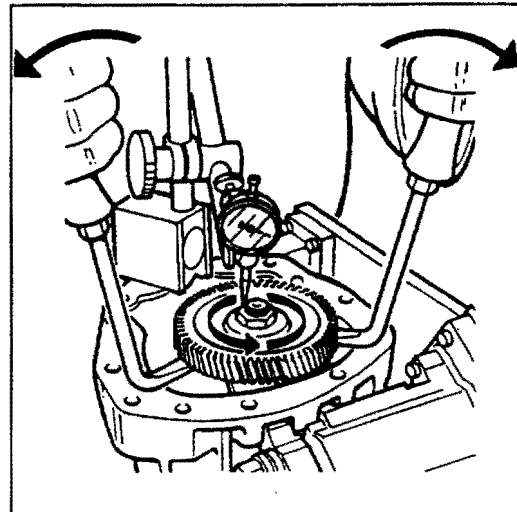

Figure IV7-5

## IV Assembly

### 8. Mount the wheel shaft and the crown gear to the housing

Insert crown gear carefully (item 1) into the housing.

Insert wheel shaft (item 2) into the housing and engage with the splines of the crown gear.

Figure IV8-1



**Do not damage the shaft seal (item 3).**

The next procedure is the adjustment of the circumferential backlash.

### 9. Measure the circumferential backlash on the crown gear and the bearing clearance on wheel shaft

#### 9.1 Measure the circumferential backlash on the crown gear

Screw the bearing adjustment unit "Q" onto the thread of the wheel shaft.

Screw 2 wheel nuts (item 1) onto the wheel bolts (item 2) and block the wheel shaft (item 3) with a lever.

Figure IV9-1

Screw the inside of the bearing adjustment unit "Q" against the wheel shaft, using a torque wrench

Tightening torque: 70 Nm (Cup springs in tool "Q" apply a force of approx. 8000 N load on the bearings)

Remove lever.



Turn the wheel shaft several times in both directions to enable the bearing rollers to align themselves.

For measuring the circumferential backlash at the crown gear, secure the pinion shaft against turning, e.g., with a wooden wedge.

Place foot of dial gauge as close as possible to 90° to the tooth flank. Turn wheel shaft in both directions and thus determine the backlash by noting the deflection of the dial gauge pointer.

The circumferential backlash is corrected by adding or removing shims (item 4).

Figure IV9-1

**Permissible circumferential backlash:**

**0.03 - 0.11 mm (0.00118 - 0.00433 in.)**

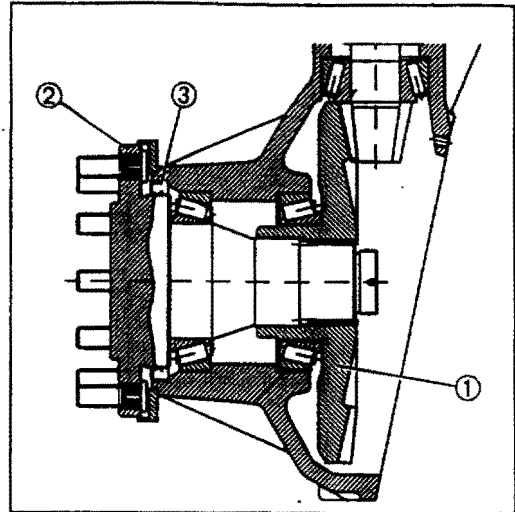

Figure IV8-1

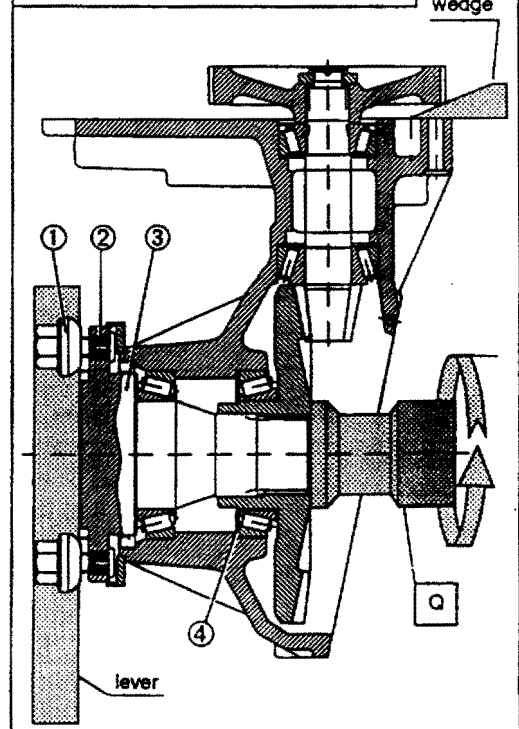
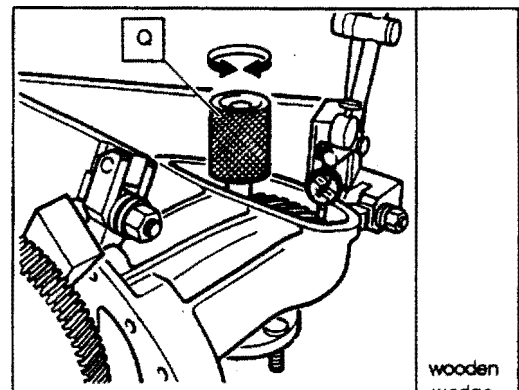

Figure IV9-1

# IV Assembly

## 9.2 Determine thickness of shims for bearing prestress

Determine the dimension Y with a dial gauge (from front end of outer part to front end of inner part of adjustment unit "Q"). Dimension Y equals the thickness of shims to be added.  
Figure IV9-2

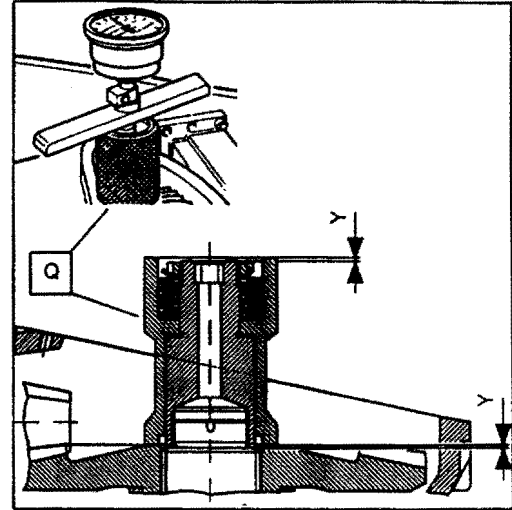

Figure IV9-2

## 9.3 Adjustment of circumferential backlash and bearing prestress

Unscrew the bearing adjustment unit "Q" and remove.

Remove wheel shaft and crown gear out of the housing.

Knock out bearing outer race with a copper mandrel.

Insert shims in required thickness for correct backlash.

Clean splines in crown gear and on wheel shaft thoroughly with suitable cleaner for example with LOCTITE fast cleaner no. 706.



**Detergents must not come into contact with the skin, nor must they be swallowed or their vapours be inhaled. Use protective gloves and glasses. If detergent has been swallowed, call the doctor immediately. Manufacturer's instructions should also be observed.**

Coat spline of crown gear (item 2) with LOCTITE no. 270.

Insert wheel shaft into the housing and engage with the splines of the crown gear.



**Do not damage the shaft seal (item 3).**

Insert shims (item 6) in required thickness for correct prestress of the bearings.

Figure IV9-3



A deviation from the measured value of minus 0.05 mm (0.002 in.) is admissible.

Screw the clamping nut (item 7) on using the socket wrench "L".  
Tightening torque: 350 Nm (258 ft-lb)



A direct control of the prestress of the taper roller bearings is not possible now. When checking according to the above procedure, make sure no clearance can be measured at the bearings. It should be possible, however, to turn the wheel shaft by hand.

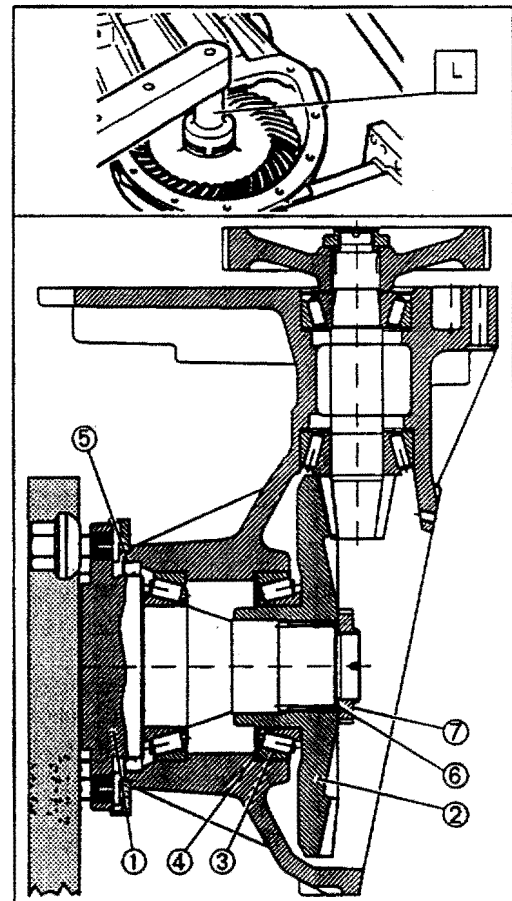

Figure IV9-3

After tightening, stake the nut to the wheel shaft.

# IV Assembly

## 10. Checking the tooth pattern

For checking the tooth contact pattern it is necessary to coat 3-4 tooth flanks of the crown gear with ink. The coated flanks are then brought several times into mesh with the conical pinion. The contact pattern will be shown more clearly if the pinion shaft is slightly braked during this operation.



The pattern thus obtained should then be compared to the pattern provided with regard to size and operation. The table below shows the prescribed patterns.

Slight deviations from the ideal size are possible and allowed. They are primarily due to different contact pressure while taking the pattern.

If significant divergences are found it must be checked whether the mounting dimensions have been kept correctly. As a rule, wrong contact patterns are due to wrong mounting dimension. Only if incorrect patterns are obtained after having rechecked the mounting dimensions, the position of the pattern may be corrected according to the rules of the diagram below.

After the tooth pattern check secure the hexagon nut (item 3, Figure IV7-2) by staking.

### Assembly guideline

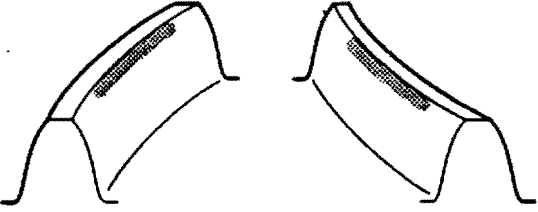
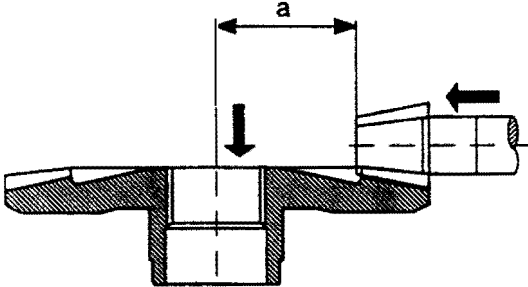
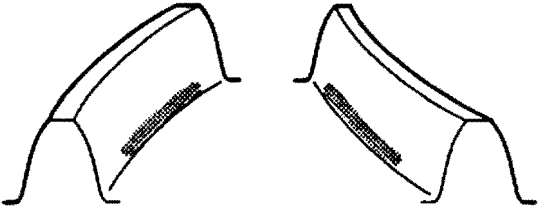
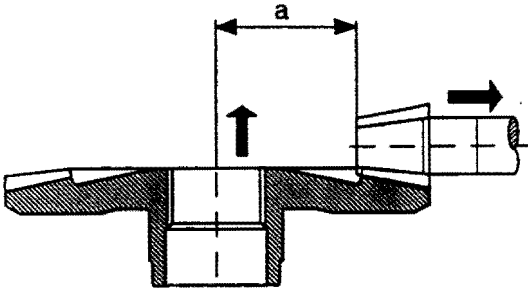
Concave flank 	Convex flank 
Tooth pattern on the crown gear Defective patterns	Correct pattern adjustment by changing the mounting dimensions in direction of arrow
<b>① Pattern at tip</b> 	
<b>② Pattern at root</b> 	

### Setting instructions

Every gear train to be mounted always according to the marked installation dimension (a).

The installation dimension (a) may only be modified if tooth patterns are not correct. The size of modification depends on the position of tooth patterns.

## IV Assembly

---

### 11. Mount the transmission cover

Coat the cover surface thinly and uniformly with LOCTITE surface seal no. 574.

Coat the threads of hexagon screws (item 1) with one drop each of LOCTITE 242.

Screw housing cover (item 2) onto the housing with hexagon screws (item 1)

Tightening torque: 23 Nm (17 ft-lb)

Figure IV11-1

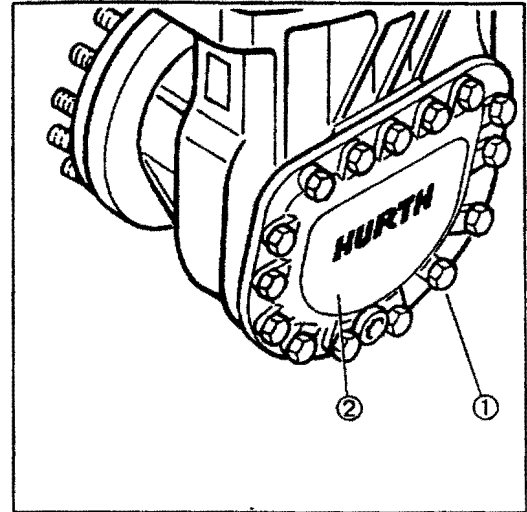

Figure IV11-1

# IV Assembly

## 12. Upper part assembly and mounting onto transmission

### 12.1 Mounting of trunnion bearing and supporting ring

Press new trunnion bearing (item 1) onto the upper part up to the stop.

Determine dimension A and B according to figure IV12-1.

Figure IV12-1

Calculate thickness of shims (item 2) to achieve bearing prestress.

Dimension A - Dimension B - 0.05 to 0.25 mm = Bearing prestress



In order to achieve bearing prestress there must be a gap of 0.05-0.25 mm (0.002-0.01 in.) between the shims and the supporting ring (item 3). Play or too high prestress influence negatively the lifetime of the bearing.

Fit required thickness of shims.

Give LOCTITE 242 on the threads of the socket head screws M10 (item 4) and tighten them cross-wise.

Tightening torque: 46 Nm

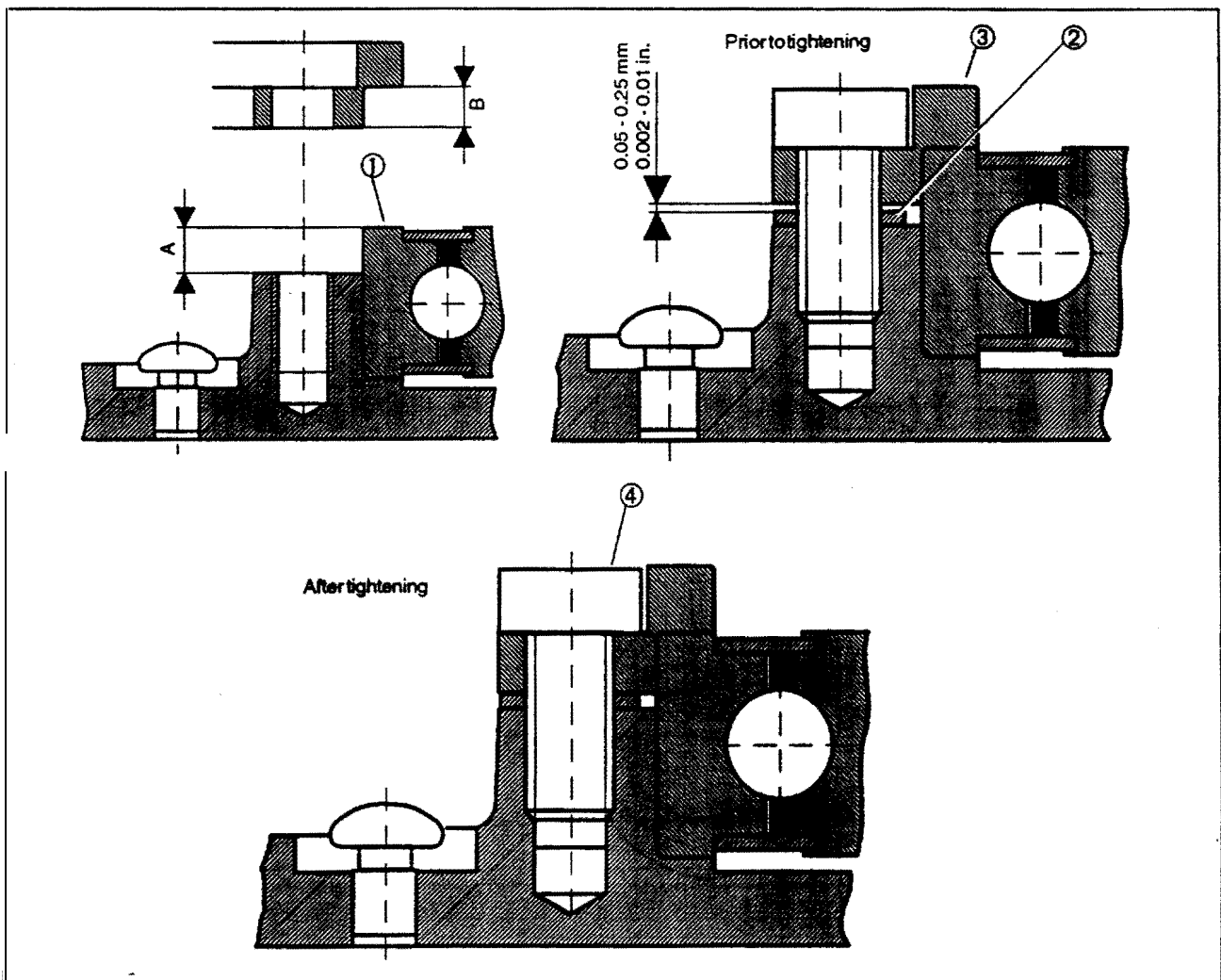

Figure IV12-1

# IV Assembly

## 12. Upper part assembly and mounting onto transmission

### 12.2 Mount upper part onto transmission

Coat surface of transmission with LOCTITE 574.

Knock pin (item 1) into the bore of the transmission. Put upper part onto transmission and align with the pin. Knock gently onto upper part till surfaces meet.

Insert socket head screws (item 2) and tighten them.

Tightening torque: M10 - 46 Nm (34 ft-lb)

M12 - 77 Nm (57 ft-lb)



The upper part is fixed in addition with 2 socket head screws (item 3) and hexagon nuts (item 4).

Tightening torque: 46 Nm (34 ft-lb)

Put centering ring (item 5) onto the bearing and secure it with hexagon screws.

Figure IV12-2

### 12.3 Mount breather valve

Use tools "S" and knock in the breather valve.

Note dimension (max. 0.5 mm / 0.02 in.)

Figure IV12-2

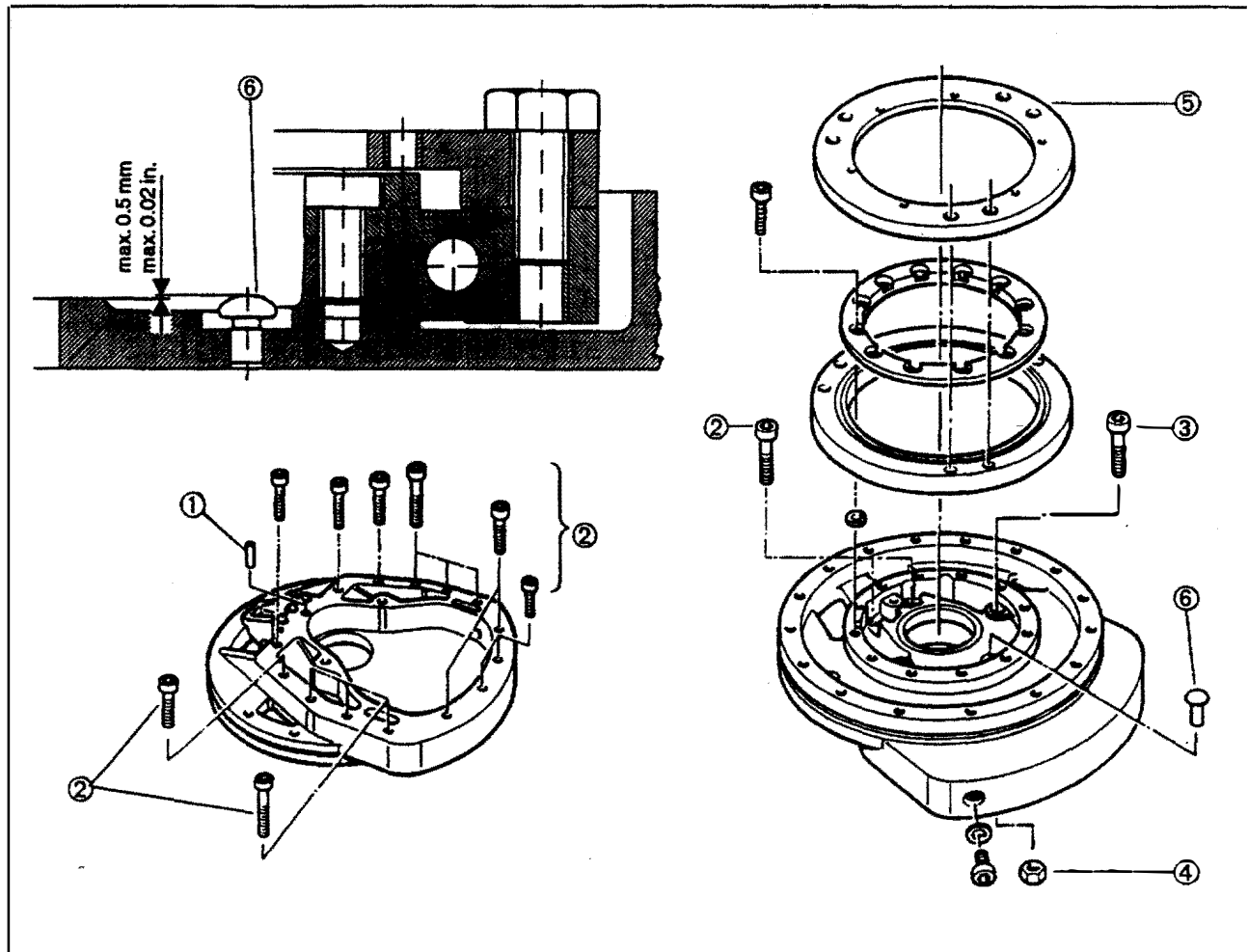

Figure IV12-2



## V Adjusting data

---

### Adjusting data

Prestress pinion shaft	0.02 - 0.07 mm (0.0008 - 0.0028 in.), tightening torque: 60 Nm (44 ft-lb)
Prestress Wheel shaft	adjusted with shims determined by tool "Q" with spring load of 8000 N (1798 lb)
Circumferential backlash	0.03 - 0.11 mm (0.00118 - 0.00433 in.)
Installation dimension breather valve	max. 0.5 mm (0.02 in.)      see Figure IV12-1
Prestress trunnion bearing	0.05 - 0.25 mm (0.002 - 0.01 in.)      see Figure IV12-1

### Tightening torques

Hexagon nut for securing helical gear:	200 Nm (148 ft-lb) locked by staking
Clamping nut on wheel shaft:	350 Nm (258 ft-lb) locked by staking
Housing cover screws:	23 Nm (17 ft-lb)
Oil drain and oil filling plugs:	22 Nm (16 ft-lb)
Mounting screws for upper part of transmission:	M10 46 Nm (34 ft-lb) M12 77 Nm (57 ft-lb)
Wheel nuts:	140 Nm (103 ft-lb)

## VI Function test

The transmission should be submitted to a function test after mounting.

For that purpose, the transmission has to be filled with oil, an electric motor and a drive wheel should be mounted. Please note the Owner's Manual and the Installation Manual.

Start the electric motor and let it run for several minutes at different speeds and in various directions of rotation at a time. At the same time, the drive wheel should be slightly braked.

Carry out a visual inspection and watch for irregular running noise.

Fault	Possible cause	Remedy
1. Oil leakage at the wheel shaft	- Shaft seal wrongly mounted or damaged	- Dismount wheel shaft and mount radial shaft seal correctly
	- Running surface on the wheel shaft damaged	- Dismount wheel shaft. Check wheel shaft running surface for reusability; rework if possible
2. Oil leakage at the housing cover	- Housing cover is not sealed	- Seal housing cover with LOCTITE 574
	- Housing cover surface or housing plane surface are not even	- Finish plane surface with a fine grinding stone
	- Screws are not sealed or have not been tightened with the correct torque	- Seal screws with LOCTITE 242 and tighten with the correct torque
3. Oil leakage at the oil filling or oil drain plug	- There is dirt between the shaft seal and the housing	- Clean
	- An old shaft seal was used	- Use a new shaft seal
	- Screws have not been tightened with the correct torque	- Tighten screws with the correct torque
4. Oil leakage between the housing and the upper part	- Sealing surface have not been sealed or are not even	- Coat sealing surface with LOCTITE 574 - Finish sealing faces with a fine grinding stone
	- Screws have not been tightened with the correct torque	- Tighten screws with the correct torque
5. Knocking noise at the train of cylindrical spur gears	- The gearing at the drive pinion and/or at the cylindrical spur gear is damaged due to incorrect mounting	- Check tooth flanks for shock damages and finish damaged parts with the a fine grinding stone
6. Ringing noise	- The train of cylindrical spur gears is running without oil	- Check the oil level, refill with oil
7. Churning noise	- The bearing preload or circumferential backlash have not been adjusted correctly	- Check and adjust correctly
8. The trunnion bearing can only be turned with difficulty or a bearing clearance is perceptible	- The bearing preload have not been adjusted correctly	- Check and adjust correctly
	- The cover disk has come loose and dirt has entered the bearing	- Replace trunnion bearing
	- Cage segments are damaged	- Replace trunnion bearing
	- Plastic deformation of the balls or the ball races	- Replace trunnion bearing

# VII Storage/Commissioning

---

## 1. Storage

After the trial run to which every transmission is submitted with the prescribed transmission oil, a certain amount of fluid will remain in the housing after draining. An internal preservation is thereby ensured, providing an anticorrosion protection for at least one year if the transmission is stored in dry conditions.

If it is intended to shut the mounted transmission down for a considerable time, it should be filled with the prescribed transmission oil (see paragraph 2). Assure that all internal parts are wetted with transmission oil and drain oil again. For longer storage time repeat this procedure every year. Any non coated interface has to be treated with an anticorrosive agent. The opening for the motor has to be closed.

Before start-up, specifically after a longer storage time, we recommend to flush the transmission with the described transmission oil.

## 2. Commissioning

**Fill the transmission with transmission oil conforming with specification API GL 4 or MIL L 2105.**

### Viscosity classes:

Standard oil:

Ambient temperature: 0 - 40 °C            SAE 80 - 90

Low-temperature oil:

Ambient temperature: down to -26 °C    SAE 80W

Ambient temperature: down to -40 °C    SAE 75W

For special use or if synthetic oil is used for the transmission, it is indispensable to consult RICO.



The oil level should be checked again after a short period at operation. If necessary, top up oil level. Refill only with the same type of oil as used for first filling.

**Required oil quantity: 7 liters**

**The oil quantities are only for ordering and disposing purposes.**

Fill fluid slowly in using a hopper. Wipe overflow fluid off with a rag.

Mount the transmission into the vehicle according to manual "installation, commissioning, maintenance" and to the instructions issued by the vehicle manufacturer.