



RICO Model # HSD-EX-AC-60

EX-60 |||

Sit-Down, Counterbalanced Explosion Proof Forklift

APPROVED FOR OPERATION IN:

- Class 1, Division 1 & 2, Group D
- Class 2, Division 1 & 2, Group G
- Hazardous Environment

Flexible Conduit (FC) Cables



For more information, or to find
your nearest Yale® dealer, go to:
www.Yale.com

RICO |

Since 1984 RICO Manufacturing has been designing and manufacturing specialized lift trucks for the most rigorous and demanding industries around the globe.



RICO's hazardous products division continues to be the leading manufacturer of Explosion Proof equipment and forklifts in the United States.

RICO's standard for excellence in design, manufacturing and installation results in the best EX-rated lift trucks on the market today. All of our explosion-proof lift trucks are designed around operator visibility, friendly maintenance and outstanding parts/service support.



98%
WORK PERFORMED
IN-HOUSE

\$
FINANCIALLY
INDEPENDENT

SAFETY FEATURES

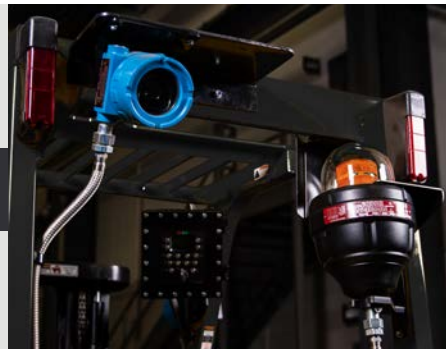

Safety is a critical focus for every successful organization – forklift safety starts with RICO.



STATIC CONDUCTIVE STEER TIRES
Prevent sparks, helping to provide a working environment with reduced peril and hazardous conditions.



PROTECTED SURFACES
Exposed components on the perimeter of the truck, including forks, are protected with brass and aluminum alloys eliminating the possibility of mechanical sparking.



RIGOROUS TESTING
Built to UL583 specifications, and approved by FM Global, a Nationally Recognized Testing Laboratory.



OUTSTANDING VISIBILITY
Excellent visibility helps increase operator awareness.



LIGHTING
Additional packages for LED work lights, blue pedestrian light and LED strobe light are available.



Choose RICO for exceptional performance and explosion proof features.

DRIVE, PUMP AND ELECTRICAL ENCLOSURES
House only electrical components and are approved to be included on EX-rated lift trucks. All RICO enclosures have been tested for approval in an EX-rated environment by FM Global.



FLEXIBLE CONDUIT (FC) CABLES house regular cabling, which is sealed to ensure safe use in an EX-rated environment. The FC Cable provides flexibility and space saving.

FEATURES & BENEFITS

EX-60

RICO Model # HSD-EX-AC-60



EASE OF MAINTENANCE

Easy access enclosure design.



REDUCED COSTS

Battery box eliminates the need for an EX battery.



INVENTORY CONTROL

Industry standard components for local servicing dealer sourcing.



APPROVED FOR OPERATION IN:

- Class 1, Division 1 & 2, Group D
- Class 2, Division 1 & 2, Group G
- Hazardous Environment

SPECIFICATIONS

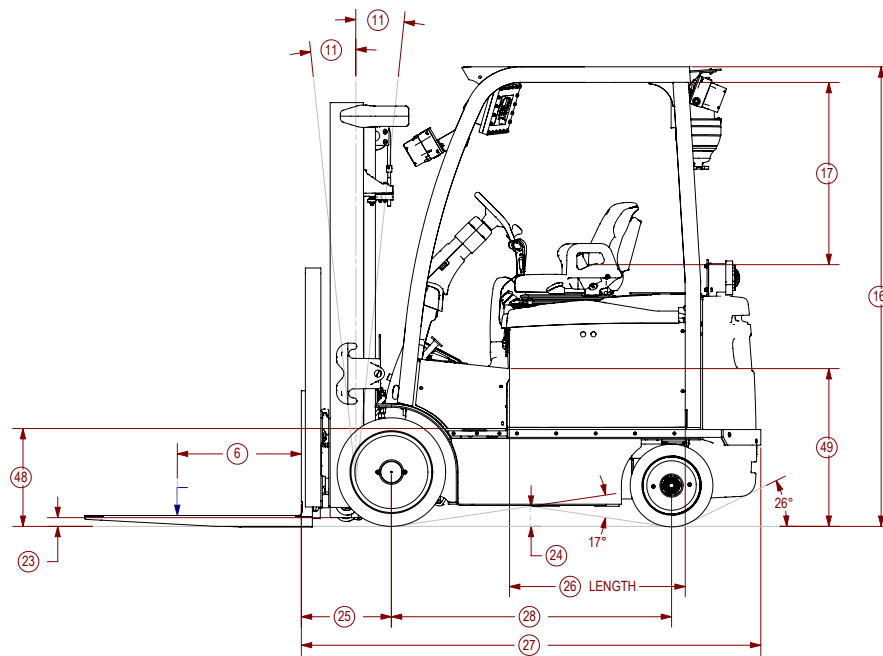
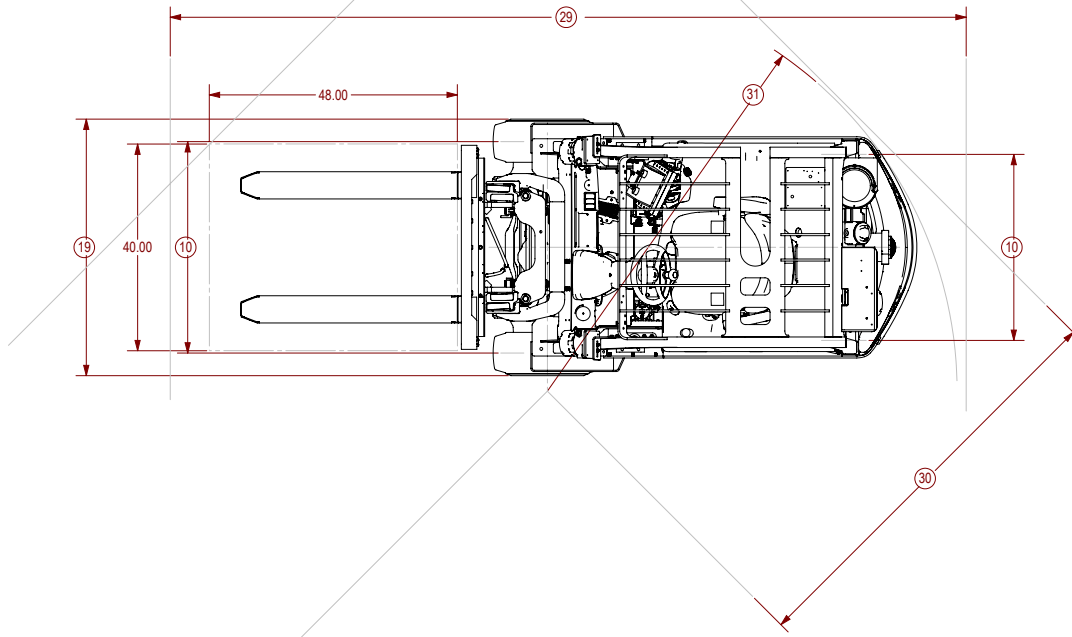

GENERAL

1	Manufacturer				RICO
2	Model Design				HSD-EX-AC-60
3	Power				Electric
4	Operation				Sit
5	Rated Capacity			lb (kg)	6,000 (2,722)
6	Load Center			in (mm)	24 (610)

TIRES

7	Tire Type – Cushion, Solid, Pneumatic, etc.		Drive/Steer		Cushion / Cushion
8	Tire Size		Drive/Steer	In	21 x 8 x 15 / 16 x 6 x 10.5
9	Wheels – Number	X-Driven	Drive/Steer		2X / 2
10	Tread	∅ Tires	Std Dr / Wide Dr / Steer	in (mm)	35.6 / 40.9 / 36 (905 / 1,039 / 915)



DIMENSIONS					
11	Mast Tilt		Std Opt Opt	degrees	5F/5B 10F / 5B (5F / 4B)
12	Mast-Lowered Height		Std Mast	in (mm)	83 (2,085)
13	Free Lift – Top of Fork	Std 2 Stg Limited Free Lift Mast		in (mm)	5 (140)
14	Opt 2 Stg Full Free Lift Mast with/without LBR			in (mm)	33/56 (855 / 1,440)
15	Lift Height-Top of Fork	Std 2 Stg Limited Free Lift Mast		in (mm)	118 (3,009)
16	Mast – Extended Height	Std Mast with / without LBR		in (mm)	167/144 (4,235 / 3,655)
17	Overhead Guard Height	Std/Drive in Rack / Opt / Opt Flat Plate		in (mm)	88.5 / 88.5 / 86.5 / 84.1 (2,248 / 2,248 / 2,197 / 2,137)
18	SIP to Bottom Std OHG	Susp at Mid-Point Std / Susp / Swivel		in (mm)	38.3 / 37.4 / 37.3 (975 / 950 / 948)
19	Overall width	Standard Tread / Wide Tread		in (mm)	43.6/48.9 (1,108 / 1,242)
20	Forks	Thickness x Width x Length		in (mm)	2 x 4.9 x 42 (50 x 125 x 1,067)
21	Standard Carriage Width		Class II	in (mm)	38.5 (977)
22	Floor to Battery Compartment			in (mm)	17.2 (436)
23	Ground Clearance	Lowest Point		in (mm)	3.6/3.3 (91 / 85)
24	Ground Clearance	Center of Truck		in (mm)	3.7/3.6 (94 / 92)
25	Load Distance	Center of Wheel to Face of Forks		in (mm)	15.8 (402)
26	Battery Compartment	Height		in (mm)	20.75 (527.05)
		Width		in (mm)	29.19 (741.43)
			Nominal	SIZE	33*
		Length	Actual	in (mm)	32.52 (826)
27	Length to Face of Forks	Chassis Length		in (mm)	87.3 (2,218)
28	Wheelbase			in (mm)	54.2 (1,377)
29	Right Angle Stack			in (mm)	140.0 (3,555)
30	Equal Aisle	90° Intersecting Angle		in (mm)	75.0 (1,904)
31	Outside Turning Radius			in (mm)	76.1 (1,934)

WEIGHT					
32	Truck Weight	Without Battery	NL	lb (kg)	945 (4,289)
33	Axle Loading – Drive	Static w / Max. Wt. Battery	NL / RL	lb (kg)	4,700 / 15,093 (2,132 / 6,846)
34	Axle Loading – Steer	Static w / Max. Wt. Battery	NL / RL	lb (kg)	6570 / 2,177 (2,980 / 987)

PERFORMANCE					
35	Travel Speed		NL/RL	mph (km / h)	7.02 / 7.02(11.3 / 11.3)
36	Lift Speed	3 Stg FFL Mast	NL/RL	ft/min (m / sec)	36 / 36 (.18 / .18)
37	Lower Speed	3 Stg FFL Mast	NL/RL	ft/min (m / sec)	79 / 104 (0.4 / .53)
38	Gradeability	5 Minute Rating	Max Grade	%	19
		60 Minute Rating	Max Grade	%	6
39	Brake	Method of Control	Service / Parking		Hydraulic / Mechanical
		Method of Operation	Service / Parking		Foot / Foot

ELECTRIC					
40	Battery			Type	Lead Acid
				VOLTS	36
41	Traction Motor	60 Minute Rating		hp (kW)	24.7 (18.4)
42	Pump Motor	15% Rating		hp (kW)	16.6 (12.4)
43	Traction Motor	Type / Control Method			AC / Transistor
44	Pump Motor	Type / Control Method			AC / Transistor
45	Number of Speeds	Traction/Pump			Infinitely Variable / Infinitely Variable

OTHER					
46	Step Height			in (mm)	18.7 (475)
47	Floor Height	Lowest Point		in (mm)	30.4 (772)
48	Attachment Relief Pressure			psi (bar)	2250 (155)
49	Auxiliary Oil Flow	3rd and 4th Function		gal/min (l / min)	11 (40)
50	Sound Level	Measured per ANSI B56.11.5	dB (A)	60	

BATTERY AND COMPARTMENT SPECIFICATIONS.

Battery Compartment Dimensions				Battery Dimensions and Specifications									
Compartment Type	Width	Length	Height	"X"		"Y"		"Z"	Volts	No. of Cells	Max Capacity 6 Hour Rate	Weight	
				Min	Max	Min	Max					Max	Min
	in (mm)			in (mm)					amp hr (kwh)		lb (kg)		
Vertical Removal (Battery Rollers)	29.19 (741.43)	32.52 (826)	20.75 (527.05)	28.75 (703.25)	29 (736.6)	32.13 (816.1)	32.38 (822.45)	20 (508)	36	18	675 (23.6)	1,710 (776)	1,890 (857)

Note: Specifications included in the tables above are subject to change.

SERVICES & SUPPORT

At RICO, we know that once a lift truck ships, the real work is just beginning!



RICO products are fully supported throughout their service life by a team of dedicated experts who are true business partners.



RICO offers EX compliance evaluations and services on all RICO manufactured trucks.

On-site evaluations can be performed by RICO or one of our factory-trained authorized servicing dealers.



RICO provides our customers with the education and tools to evaluate and assess EX trucks in the field to determine whether they are still within compliance.

ROI

Extend the return on investment of your vehicle and ensure the safety of your team and your facility — schedule an EX compliance evaluation or EX training today.



For more information, or to find your nearest Yale® dealer, go to:

www.Yale.com



Join the Conversation



RICO is American
Owned & Operated

RICO Manufacturing, Inc.
691 West Liberty Street
Medina, OH 44256
330.723.4050
www.RICOequipment.com

RICO