



RICO Model # HSD-EX-AC-30

EX-30 ||||

Sit-Down, Counterbalanced Explosion Proof Forklift

APPROVED FOR OPERATION IN:

- Class 1, Division 1 & 2, Group D
- Class 2, Division 1 & 2, Group G
- Hazardous Environment



For more information, or to find
your nearest Hyster® dealer, go to:
www.Hyster.com

RICO |

Since 1984 RICO Manufacturing has been designing and manufacturing specialized lift trucks for the most rigorous and demanding industries around the globe.

RICO's hazardous products division continues to be the leading manufacturer of Explosion Proof equipment and forklifts in the United States.

RICO's standard for excellence in design, manufacturing and installation results in the best EX-rated lift trucks on the market today. All of our explosion-proof lift trucks are designed around operator visibility, friendly maintenance and outstanding parts/service support.



98%
WORK PERFORMED
IN-HOUSE



FINANCIALLY
INDEPENDENT

SAFETY FEATURES

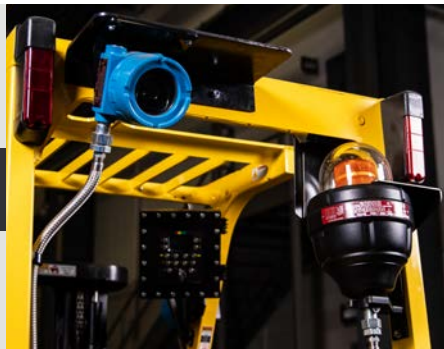

Safety is a critical focus for every successful organization – forklift safety starts with RICO.



STATIC CONDUCTIVE STEER TIRES

Prevent sparks, helping to provide a working environment with reduced peril and hazardous conditions.



PROTECTED SURFACES

Exposed components on the perimeter of the truck, including forks, are protected with brass and aluminum alloys eliminating the possibility of mechanical sparking.



RIGOROUS TESTING

Built to UL583 specifications, and approved by FM Global, a Nationally Recognized Testing Laboratory.



OUTSTANDING VISIBILITY

Excellent visibility helps increase operator awareness.



LIGHTING

Additional packages for LED work lights, blue pedestrian light and LED strobe light are available.



Choose RICO for exceptional performance and explosion proof features.

DRIVE, PUMP AND ELECTRICAL ENCLOSURES
House only electrical components and are approved to be included on EX-rated lift trucks. All RICO enclosures have been tested for approval in an EX-rated environment by FM Global.



FLEXIBLE CONDUIT (FC) CABLES house regular cabling, which is sealed to ensure safe use in an EX-rated environment. The FC Cable provides flexibility and space saving.

FEATURES & BENEFITS

EX-30

RICO Model # HSD-EX-AC-30



EASE OF MAINTENANCE

Easy access to serviceable components.



REDUCED COSTS

Battery box eliminates the need for an EX battery.



INVENTORY CONTROL

Industry standard components for local servicing and dealer sourcing.



EXCEPTIONAL MANEUVERABILITY

Compact design increases ability to operate in narrow aisles or small spaces.



APPROVED FOR OPERATION IN:

- Class 1, Division 1 & 2, Group D
- Class 2, Division 1 & 2, Group G
- Hazardous Environment

SPECIFICATIONS

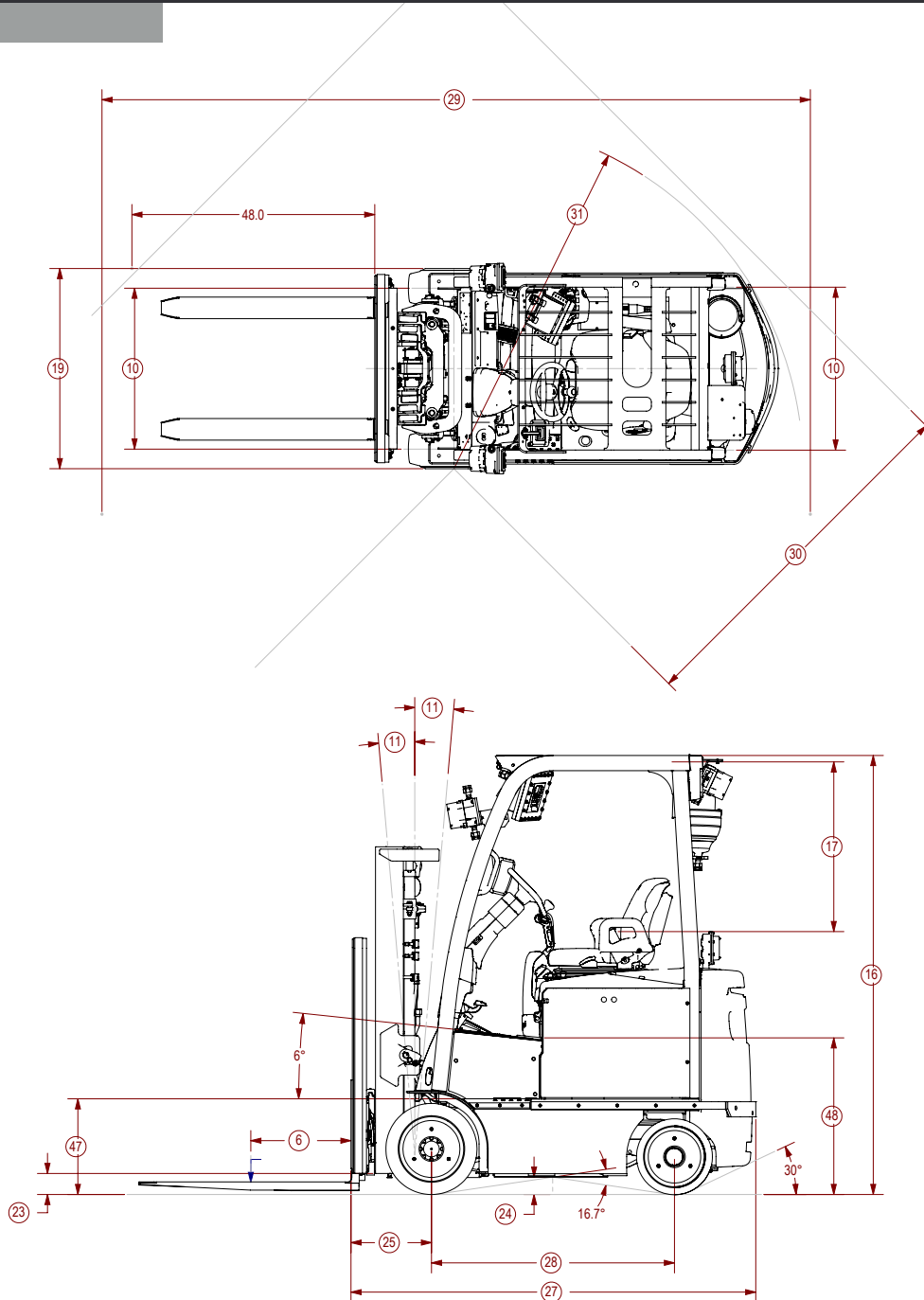

GENERAL

1	Manufacturer			RICO
2	Model Designation			HSD-EX-AC-30
3	Power			Electric
4	Operation			Sit
5	Rated Capacity		lb (kg)	3,000 (1,361)
6	Load Center		in (mm)	24 (610)

TIRES

7	Tire Type - Cushion, Solid, Pneumatic, etc.		Drive / Steer		Cushion / Cushion
8	Tire Size	Std	Drive / Steer	in	18 x 7 x 12.1 / 15 x 5 x 11.25
		Opt	Drive / Steer	in	N/A / N/A
9	Wheels - Number	X=Driven	Drive / Steer		2X / 2
10	Tread - Drive	Center of Tires		in (mm)	31.8 (808)
	Tread - Steer	Center of Tires		in (mm)	32.2 (817)



DIMENSIONS

11	Mast Tilt	Std Opt		degrees	5F / 5B 10F / 5B
12	Mast - Lowered Height	Std Mast		in (mm)	82.13 (2,086)
13	Free Lift - Top of Fork	Std 2 Stg Limited Free Lift Mast		in (mm)	5.13 (130)
		Opt 2 Stg Full Free Lift Mast with / without LBR		in (mm)	31.13 / 57.13 (790 / 1,451)
14	Lift Height - Top of Fork	Std 2 Stg Limited Free Lift Mast		in (mm)	127.13 (3,229)
15	Mast - Extended Height	Std Mast with / without LBR		in (mm)	176 / 150 (4,455 / 3,806)
16	Overhead Guard Height	Std & DIR		in (mm)	88.5 (2,248)
17	SIP to Underside OHG	Susp at Mid-Point	Std / Full Susp	in (mm)	38.7 / 37.3 (984 / 949)
19	Overall Width			in (mm)	39.6 (1,005)
20	Forks	Thickness x Width x Length		in (mm)	1.75 x 4.25 x 42 (44 x 108 x 1,067)
21	Standard Carriage Width	Class II		in (mm)	35.7 (907)
22	Floor to Top of Battery Rollers			in (mm)	19.25 (489)
23	Ground Clearance	Lowest Point	NL / RL	in (mm)	3.4 (86)
		Center of Truck	NL / RL	in (mm)	3.4 (86)
25	Load Distance	Center of Wheel to Face of Forks		in (mm)	15.9 (404)
26	Battery Compartment	Height	Battery Rollers	in (mm)	20 (508)
		Width		in (mm)	26.75 (679)
		Length		in (mm)	26.3 (660)
27	Length to Face of Forks	Chassis Length		in (mm)	77.5 (1,968)
28	Wheelbase			in (mm)	48 (1,220)
29	Right Angle Stack			in (mm)	129.5 (3,289)
30	Equal Aisle	90° Intersecting Aisle		in (mm)	70 (1,778)
31	Outside Turning Radius			in (mm)	66 (1,676)

WEIGHT

32	Truck Weight	Without Battery	NL	lb (kg)	7,070 (3,206)
33	Axle Loading - Drive	Static with Max. Wt. Battery	NL / RL	lb (kg)	4,325 / 9,725 (1,962 / 4,411)
34	Axle Loading - Steer	Static with Max. Wt. Battery	NL / RL	lb (kg)	4,500 / 2,100 (2,041 / 953)

PERFORMANCE

				VOLTS	36
35	Travel Speed	Extended Shift OFF	NL / RL	mph (km/h)	6.9 / 6.9 (11.2 / 11.2)
36	Lift Speed	Std 2 Stg LFL Mast	NL / RL	ft/min (m/sec)	44 / 42 (.22 / .21)
		Opt 2 Stg FFL Mast	NL / RL	ft/min (m/sec)	36 / 32 (.18 / .16)
		Opt 3 Stg FFL Mast	NL / RL	ft/min (m/sec)	36 / 32 (.18 / .16)
37	Lower Speed	Std 2 Stg LFL Mast	NL / RL	ft/min (m/sec)	93 / 100 (0.47 / 0.51)
		Opt 2 Stg FFL Mast	NL / RL	ft/min (m/sec)	73 / 91 (0.37 / 0.46)
		Opt 3 Stg FFL Mast	NL / RL	ft/min (m/sec)	81 / 94 (0.41 / 0.48)
40	Brake	Method of Control	Service / Parking		Hydraulic / Mechanical
		Method of Operation	Service / Parking		Foot / Foot

ELECTRIC

41	Battery	Type			Lead Acid
42	Traction Motor	60 Minute Rating		hp (kW)	24.7 (18.4)
43	Pump Motor	S3-15%		hp (kW)	21.5 (16)
44	Traction Motor	Type / Control Method			AC / Transistor
45	Pump Motor	Type / Control Method			AC / Transistor
46	Number of Speeds	Traction / Pump			Infinitely Variable / Infinitely Variable

OTHER

47	Step Height			in (mm)	18.7 (475)
48	Floor Height	Lowest Point		in (mm)	30.4 (772)
49	Attachment Relief Pressure	Mech Levers / Mini-levers		psi (bar)	2,596 / 2,596 (179 / 179)
50	Auxiliary Oil Flow	3rd Function / 4th Function		gal/min (l/min)	10.6 / 10.6 (40 / 40)

BATTERY AND COMPARTMENT SPECIFICATIONS.

Battery Compartment Dimensions				Battery Dimensions and Specifications									
Compartment Type	Width	Length	Height	"X"		"Y"		"Z"	Volts	No. of Cells	Max Capacity 6 Hour Rate	Weight	
				Min	Max	Min	Max					Max	Min
	in (mm)			in (mm)			amp hr (kwh)		lb (kg)				
Vertical Removal (Battery Rollers)	26.75 (680)	26.3 (660)	20.0 (508)	25.7 (654)	26.0 (660)	25.71 (653)	26.0 (660)	19.8 (503)	36	18	450 (16.2)	1,550 (703)	1,750 (794)

Note: Specifications included in the tables above are subject to change.

SERVICES & SUPPORT

At RICO, we know that once a lift truck ships, the real work is just beginning.



RICO products are fully supported throughout their service life by a team of dedicated experts who are true business partners.



RICO offers EX compliance evaluations and services on all RICO manufactured trucks.

On-site evaluations can be performed by RICO or one of our factory-trained authorized servicing dealers.



RICO provides our customers with the education and tools to evaluate and assess EX trucks in the field to determine whether they are still within compliance.

ROI

Extend the return on investment of your vehicle and help increase the safety of your team and your facility — schedule an EX compliance evaluation or EX training today.



For more information, or to find your nearest Hyster® dealer, go to:

www.Hyster.com



Join the Conversation



RICO is American
Owned & Operated

RICO Manufacturing, Inc.
691 West Liberty Street
Medina, OH 44256
330.723.4050
www.RICOequipment.com

RICO