

<b>GENERAL</b>	1	Manufacturer			RICO Manufacturing		
	2	Model Design			HSD-EX-60		
	3	Power			Electric		
	4	Operation			Sit		
	5	Rated Capacity		lb (kg)	6000 (2722)		
	6	Load Center		in (mm)	24 (610)		
<b>TIRES</b>	7	Tire Type - Cushion, Solid, Pneumatic, etc.	Drive/Steer		Cushion / Cushion		
	8	Tire Size	Drive/Steer	in	21 x 8 x 15 / 16 x 6 x 10.5		
	9	Wheels - Number	X=Driven	Drive/Steer		2X / 2	
	10	Tread	φ Tires	Std Dr/Wide Dr/Steer	in (mm)	35.6/40.9/36 (905/1039/915)	
<b>DIMENSIONS</b>	11	Mast Tilt		Std Opt Opt	degrees	5F/5B 10F/5B (5F/4B)	
	12	Mast - Lowered Height		Std Mast	in (mm)	83 (2085)	
	13	Free Lift - Top of Fork	Std 2 Stg Limited Free Lift Mast		in (mm)	5 (140)	
	14	Opt 2 Stg Full Free Lift Mast with/without LBR			in (mm)	33/56 (855/1440)	
	15	Lift Height-Top of Fork	Std 2 Stg Limited Free Lift Mast		in (mm)	118 (3009)	
	16	Mast - Extended Height	Std Mast with/without LBR		in (mm)	167/144 (4235/3655)	
	17	Overhead Guard Height	Std/Drive in Rack/Opt/Opt Flat Plate		in (mm)	88.5/88.5/86.5/84.1 (2248/2248/2197/2137)	
	18	SIP to Bottom Std OHG	Susp at Mid-Point	Std/Susp/Swivel	in (mm)	38.3/37.4/37.3 (975/950/948)	
	19	Overall Width	Standard Tread/Wide Tread		in (mm)	43.6/48.9 (1108/1242)	
	20	Forks	Thickness x Width x Length		in (mm)	2 x 4.9 x 42 (50 x 125 x 1067)	
	21	Standard Carriage Width		Class II	in (mm)	38.5 (977)	
	22	Floor to Battery Compartment			in (mm)	17.2 (436)	
	23	Ground Clearance	Lowest Point		in (mm)	3.6/3.3 (91/85)	
	24	Ground Clearance	Center of Truck		in (mm)	3.7/3.6 (94/92)	
	25	Load Distance	Center of Wheel to Face of Forks		in (mm)	15.8 (402)	
	26	Battery Compartment	Height		in (mm)	20.75 (527.05)	
			Width		in (mm)	29.19 (741.43)	
				Nominal	SIZE	33"	
			Length	Actual	in (mm)	32.52 (826)	
	27	Length to Face of Forks	Chassis Length		in (mm)	87.3 (2218)	
	28	Wheelbase			in (mm)	54.2 (1377)	
	29	Right Angle Stack			in (mm)	140.0 (3555)	
	30	Equal Aisle	90° Intersecting Aisle		in (mm)	75.0 (1904)	
	31	Outside Turning Radius			in (mm)	76.1 (1934)	
	<b>WT.</b>	32	Truck Weight	Without Battery	NL	lb (kg)	945 (4289)
		33	Axle Loading - Drive	Static w/Max. Wt. Battery	NL/RL	lb (kg)	4700/15093 (2132/6846)
34		Axle Loading - Steer	Static w/Max. Wt. Battery	NL/RL	lb (kg)	6570/2177 (2980/987)	
<b>PERFORMANCE</b>					VOLTS	36v Standard Performance Only	
	35	Travel Speed		NL/RL	mph (km/h)	7.02/7.02 (11.3/11.3)	
	36	Lift Speed	3 Stg FFL Mast	NL/RL	ft/min (m/sec)	36/36 (.18/.18)	
	37	Lower Speed	3 Stg FFL Mast	NL/RL	ft/min (m/sec)	79/104 (0.4/.53)	
	38	Gradeability	5 Minute Rating	Max Grade	%	19	
			60 Minute Rating	Max Grade	%	6	
	39	Brake	Method of Control	Service/Parking		Hydraulic/Mechanical	
		Method of Operation	Service/Parking		Foot/Foot		
	Battery	Type			Lead Acid		
				VOLTS	36		
<b>ELECTRIC</b>	40	Traction Motor	60 Minute Rating		hp (kW)	24.7 (18.4)	
	41	Pump Motor	15% Rating		hp (kW)	16.6 (12.4)	
	42	Traction Motor	Type/Control Method			AC / Transistor	
	43	Pump Motor	Type/Control Method			AC / Transistor	
44	Number of Speeds	Traction/Pump			Infinitely Variable / Infinitely Variable		
<b>OTHER</b>	45	Step Height			in (mm)	18.7 (475)	
	46	Floor Height	Lowest Point		in (mm)	30.4 (772)	
	47	Attachment Relief Pressure			psi (bar)	2250 (155)	
	48	Auxiliary Oil Flow	3rd and 4th Function		gal/min (l/min)	11 (40)	
	49	Sound Level	Measured per ANSI B56.11.5		dB (A)	60	



**APPROVED FOR OPERATION IN**  
 CLASS 1, DIVISION 1 & 2, GROUP D  
 CLASS 2, DIVISION 1 & 2, GROUP G  
 HAZARDOUS ENVIRONMENT



## HSD-EX-60 BATTERY AND BATTERY COMPARTMENT SPECIFICATIONS

50	Battery Compartment	W/L/H	in (mm)	29.19 x 32.52 x 20.75 (741.43 x 826 x 527.05)
51	Battery Dimensions	W/L/H	in (mm)	29 x 32.38 x 20 (736.6 x 822.45 x 508)
			No. of Cells	18
52	Max Capacity 6 Hour Rate		amp hr (kwh)	675 (23.6)
52	Battery Weight	Min	lb (kg)	1710 (776)
		Max	lb (kg)	1890 (857)
54	Battery Information:	Modified EnerSys 18-E75L-19 or Similar / Reference# 510704L-WGRN / Modified to have lifting ears on the long side SB-350 Gray Connector / 675 AH / No Cover / 2/0 Cable Required / 36" Cable Leads / Termination Position B / UL E Rated		

### BATTERY DIMENSION DRAWING

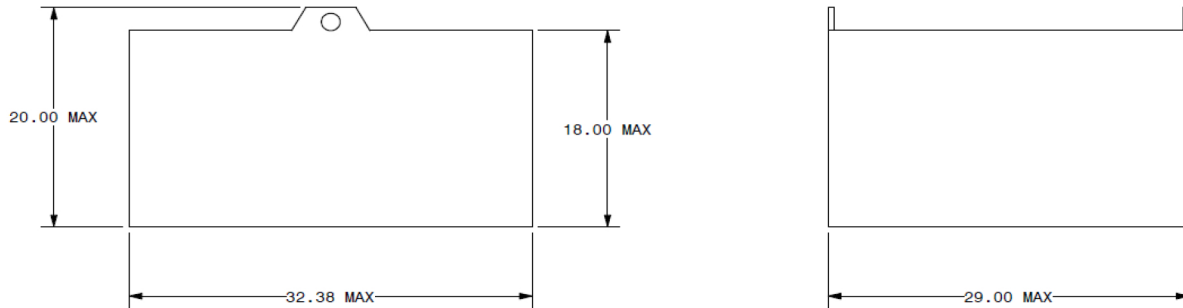

# EX-60



**APPROVED FOR OPERATION IN**  
CLASS 1, DIVISION 1 & 2, GROUP D  
CLASS 2, DIVISION 1 & 2, GROUP G  
HAZARDOUS ENVIRONMENT

For more information, or to find your nearest  
Hyster® dealer, go to [Hyster.com](http://Hyster.com)

RICO Manufacturing, Inc.  
691 West Liberty Street  
Medina, OH 44256  
330-723-4050  
[RicoEquipment.com](http://RicoEquipment.com)

