



SERIES

This user manual details the features of the following PowerpaK Series controllers and variants.

- | | | | |
|----|-----------------|------------------------|------------------|
| 1. | Traction Series | 24-48V, 300A,450A,650A | Low I/O Logic |
| 2. | “ | 72-80V, 450A,600A | Low I/O Logic |
| 3. | “ | 24-48V, 300A,450A,650A | Medium I/O Logic |
| 4. | “ | 72-80V, 450A,600A | Medium I/O Logic |
| 5. | “ | 24-48V, 300A,450A,650A | High I/O Logic |
| 6. | “ | 72-80V, 450A,600A | High I/O Logic |
| 7. | Pump Series | 24-48V, 300A,450A,650A | Pump I/O Logic |
| 8. | “ | 72-80V, 450A,600A | Pump I/O Logic |

Modification History

Revision	Issue Date	Author	Changes
Rev E	9 April 1999	P.R.G	High I/O Changes / New Variants
Rev F	27 October 1999	A.J.K.	Feature Changes and Additions
Rev G	14 September, 2001	P.S.	Additions, RS232, Wiring, Mech Details

CONTENTS

MODIFICATION HISTORY	1
1 INTRODUCTION	3
2 POWERPAK CONTROLLER VARIANTS.....	4
3 CONTROLLER FEATURES WITH THE DIFFERENT LOGIC VARIANTS.....	5
4 SAFETY	6
5 TECHNICAL SPECIFICATIONS	6
6 CONTROLLER WIRING AND CONNECTIONS.....	8
7 CALIBRATOR AND ADJUSTMENTS.....	12
8 DIAGNOSTICS	20
9 SERVICE AND FAULT LOGS (ALL LOGICS).....	21
10 CONTROLLER OPERATION AND FEATURE DESCRIPTIONS	22
11 DASHBOARD DISPLAYS - OPERATION AND FEATURE DESCRIPTIONS	31
12 POWER CIRCUIT DESCRIPTIONS	39
13 INSTALLATION.....	40
14 EMC GUIDELINES.....	41
FIGURE 1 LIGHT WIRING - LOW I/O LOGIC. (PUMP FUNCTIONS IN BRACKETS.)	45
FIGURE 2 LIGHT WIRING - MEDIUM I/O LOGIC	46
FIGURE 3 LIGHT WIRING - HIGH I/O LOGIC	47
FIGURE 4 SERIES TRACTION REGEN	48
FIGURE 5 SERIES TRACTION PLUGGING.....	49
FIGURE 6 SERIES PUMP.....	50
FIGURE 7 MECHANICAL DETAILS.....	51

1 INTRODUCTION

1.1 The PowerpaK range of Controllers uses a new concept in power switching technology to provide a full range of power frames 24V-80V, 300A-650A in one small, highly efficient package. This is achieved using a new power switching scheme and radical new construction techniques, both the subject of patent applications, which enable large powers to be incorporated into very small packages.

The PowerpaK range of controllers are available in standalone Traction and Pump formats, with the Traction offering either Regen and plug braking or plug braking only. To improve flexibility and serviceability the logic is plugged into the power frame and can be removed easily without disturbing the power connections or having to remove the power frame cover.

To further increase flexibility and tailor the controller to specific applications, there are 3 core versions of logic which vary in complexity and the amount of I/O, input and output functions, to help ensure the most cost effective controller package is offered for a particular application. The Low I/O logic is a minimum feature logic aimed at walkies and basic forklift truck applications. The Medium logic is more suitable for more sophisticated vehicles including Forklift and Reach truck types, whilst the High I/O logic is targeted at the Aerial lift market where increased I/O is required. All logics have CAN communications.

All PowerpaK controllers are microprocessor based with flexible software and setup options, and use high frequency MOSFET power switching technology. Controllers have been designed to satisfy the requirements of the relevant UL and EC standards.

PowerpaK controllers have been optimised for use with D.C. series wound motors. There is a separate range of PowerpaK SEM controllers.



2 PowerpaK CONTROLLER VARIANTS

PP xxx		Model number description	
	1st digit	Controller Type	1 = ----- 2 = Traction 3 = Pump 4 = ----- 5 = ----- 6 = ----- 7 = -- Reserved -- (SEM)
	2nd digit	Voltage Range	2 = --Reserved-- (24-36V) 4 = 24V - 48V 8 = 72V - 80V
	3rd digit	Current Limit	3 = 300A 4 = 450A 6 = 650A* (* Note 600A at 80V)
		Suffix	L = Low I/O, Traction M = Medium I/O, Traction H = High I/O, Traction P = Low I/O, Pump

MODE L	POWER	CONFIGURATION	LOGIC	NO. off Power Terminals	UNIT SIZE
PP243L	24-48V 300A	Traction Regen/Plug	Low I/O	6	142 x 142 x 140mm
PP244L	24-48V 450A	Traction Regen/Plug	Low I/O	6	142 x 142 x 140mm
PP246L	24-48V 650A	Traction Regen/Plug	Low I/O	6	142 x 142 x 140mm
PP284L	72-80V 450A	Traction Regen/Plug	Low I/O	6	142 x 142 x 140mm
PP286L	72-80V 600A	Traction Regen/Plug	Low I/O	6	142 x 142 x 140mm
PP243M	24-48V 300A	Traction Regen/Plug	Med. I/O	6	142 x 142 x 140mm
PP244M	24-48V 450A	Traction Regen/Plug	Med. I/O	6	142 x 142 x 140mm
PP246M	24-48V 650A	Traction Regen/Plug	Med. I/O	6	142 x 142 x 140mm
PP284M	72-80V 450A	Traction Regen/Plug	Med. I/O	6	142 x 142 x 140mm
PP286M	72-80V 600A	Traction Regen/Plug	Med. I/O	6	142 x 142 x 140mm
PP343P	24-48V 300A	Pump	Pump I/O	5	142 x 142 x 140mm
PP344P	24-48V 450A	Pump	Pump I/O	5	142 x 142 x 140mm
PP346P	24-48V 650A	Pump	Pump I/O	5	142 x 142 x 140mm
PP384P	72-80V 450A	Pump	Pump I/O	5	142 x 142 x 140mm
PP386P	72-80V 600A	Pump	Pump I/O	5	142 x 142 x 140mm
PP243H	24-48V 300A	Traction Regen/Plug	High I/O	6	142 x 142 x 140mm
PP244H	24-48V 450A	Traction Regen/Plug	High I/O	6	142 x 142 x 140mm
PP246H	24-48V 650A	Traction Regen/Plug	High I/O	6	142 x 142 x 140mm
PP284H	72-80V 450A	Traction Regen/Plug	High I/O	6	142 x 142 x 140mm
PP286H	72-80V 600A	Traction Regen/Plug	High I/O	6	142 x 142 x 140mm

3 CONTROLLER FEATURES WITH THE DIFFERENT LOGIC VARIANTS

Logic Feature	Pump Low I/O Logic	Traction Low I/O Logic	Traction Med. I/O Logic	Traction High. I/O Logic
Number of Connectors	2	2	3	3
Number of Digital switch inputs.	6	6	8	10
Number of Analogue inputs	2	2	2	2
Number of Contactor drive outputs (2 Amps)	0	3	5	10
24V - 80V Operation	yes	yes	yes	yes
Can cater for Current Limit range of 300A to 650A	yes	yes	yes	yes
Logic Case enclosed to IP65, Power Case to IP55	yes	yes	yes	yes
Microprocessor control	yes	yes	yes	yes
High frequency (Silent Operation)	yes	yes	yes	yes
Internal watchdog monitoring microprocessor operation	yes	yes	yes	yes
Arcless contactor switching and built in coil suppression	n/a	yes	yes	yes
Use of 24V contactors at all voltages possible	n/a	yes	yes	yes
Low impedance, active low inputs switched to B-ve	yes	yes	yes	yes
Thermally compensated current limit	yes	yes	yes	yes
Selectable accelerator characteristics	yes	yes	yes	yes
Adjustable creep speed	yes	yes	yes	yes
Bypass with over current dropout + Field Weakening	n/a	no	yes	yes
Seat switch timer	yes	yes	yes	yes
Belly switch operation	n/a	yes	no	no
Power steer contactor driver and timer	n/a	yes	yes	yes
Regenerative or plug brake only	n/a	yes	yes	yes
Braking proportional to accelerator position	n/a	yes	yes	yes
Braking in neutral	n/a	yes	yes	yes
Braking with brake pedal	n/a	yes	yes	yes
Under and Over-voltage protection	yes	yes	yes	yes
Accelerator wire off detect	n/a	yes	yes	yes
Inching and timed burst inching facilities	n/a	yes	yes	yes
Economy pot input	n/a	yes	yes	yes
Short circuit and open circuit contactor detect	n/a	yes	yes	yes
3 traction cutback speeds with independent accel delays	n/a	yes	yes	yes
6 Pump speeds with Additive, Priority & Compensation	yes	n/a	n/a	n/a
Input to disable pump operation	yes	n/a	n/a	n/a
Independent Power steer speed and compensation settings	yes	n/a	n/a	n/a
Hardware and Software fail-safe systems	n/a	yes	yes	yes
+ 12V output pin	yes	no	yes	yes
Diagnostics with LED indication	yes	yes	yes	yes
Adjustments made via a calibrator	yes	yes	yes	yes
Serial communications (external module gives RS232)	yes	yes	yes	yes
Can be setup with a PC (via above external module)	yes	yes	yes	yes
CAN serial communications	yes	yes	yes	yes
Hours count displaying Key & Pulsing hours on calibrator	yes	yes	yes	yes
BDI on Calibrator	yes	yes	yes	yes
Dual Motor Non Proportional variant with switches or pot	n/a	no	no	no
Dual Motor steer angles can be adjusted	n/a	no	no	no
Dual Motor independently ramp up/down delay adjustable	n/a	no	no	no
Speed limit facility optionally available with speed sensor	n/a	no	yes	yes
Resettable Service and Fault logs	yes	yes	yes	yes
Foreign languages selectable on calibrator	yes	yes	yes	yes
Standard + Full Feature Dashboard Display compatible	yes	yes	yes	yes
Setup menu on calibrator to enable various options	yes	yes	yes	yes
Compatible with PC-PAK	yes	yes	yes	yes

4 SAFETY

- 4.1 Electric vehicles can be dangerous. All testing, fault-finding and adjustment should be carried out by competent personnel. The drive wheels should be off the floor and free to rotate during the following procedures. THE VEHICLE MANUFACTURER'S MANUAL SHOULD BE CONSULTED BEFORE ANY OPERATION IS ATTEMPTED.
- 4.2 The PowerpaK controller contains a triple fail-safe system to give a high level of safety. If the diagnostic LED is not illuminated or flashes, the safety circuit may have tripped and the truck may not drive.
- 4.3 To ensure continued safety of the PowerpaK system, the fail-safe circuit should be checked whenever the truck is serviced . The period between checks should not exceed 3 months.
- 4.4 THE BATTERY MUST BE DISCONNECTED BEFORE REPLACING OR ATTEMPTING ANY REPAIRS OF THE CONTROLS.
- 4.5 Before working on the controls disconnect the battery and connect the B+ and B-controller terminals via a 10 ohm 25 watt resistor to discharge the internal capacitors.
- 4.6 Never connect the controller to a battery with its vent caps removed as an arc may occur due to the controller's internal capacitance when it is first connected.
- 4.7 FAIL-SAFE CHECK:
- 4.7.1 Ensure the drive wheels are CLEAR OF THE FLOOR AND FREE TO ROTATE.
- 4.7.2 Switch on, select seat switch, release brake, select direction and FS1, the wheels should rotate and the diagnostic LED should give a steady illumination.
- 4.7.3 Switch off, disconnect battery and connect the A and B- terminals together with, at least, 10mm² cable. Ensure that no other fault that would allow drive is present.
- 4.7.4 Reconnect battery, switch on key with direction in neutral. The LED should stay off. Select a direction and check that the direction contactors do not close and the wheels do not rotate.
- 4.7.5 Switch off at key and remove the A/B- connection. Switch on at key, reselect the power-up sequence and check that the LED illuminates and the truck wheels rotate.
IF THE TRUCK DRIVES IN 4.7.4 THE CONTROLLER IS FAULTY AND MUST BE REPLACED.
- 4.8 As blow-out magnets are fitted to contactors (except 24V) ensure that no magnetic particles can accumulate in the contact gaps and cause malfunction. Ensure that contactors are wired with the correct polarity to their power terminals as indicated by the + sign on the top moulding.
- 4.8 The PowerpaK controller must NOT be used with permanently-connected on-board chargers or damage to the system may result.

5 TECHNICAL SPECIFICATIONS

5.1 Electrical

5.1.1 Voltage specifications:

Model	Voltage	Nominal Battery	Absolute Maximum Operating voltage
PP x4x	48V Units	24-48V	14.5 - 75V
PP x8x	80V Units	72-80V	43.0 - 97.5V

5.1.2

Current specifications:

Model	Power	Current limit (1 min)	Safe operating Area (SOA)	Continuous Current 1 Hour rating. Unit mounted on an aluminium base-plate 780x380x10mm, at 20°C ambient.
PP x43	48V 300A	300A	30 - 60%	90A
PP x44	48V 450A	450A	30 - 60%	135A
PP x46	48V 650A	650A	30 - 60%	200A
PP x84	80V 450A	450A	25 - 45%	125A

PP x86	80V 600A	600A	25 - 45%	150A
--------	----------	------	----------	------

- 5.1.3 Switching Frequency: 16 KHz Traction/Regen/Pump Drive and 6KHz Plug Braking.
5.1.4 Electrical Isolation: Enclosure to any live part = 1KV. Controller internal insulation specified at > 10MΩ @500V DC. Dielectric strength 1000V @ 50Hz for 1 Minute.
5.1.5 Battery Polarity: A Line Contactor driven from the keyswitch, with a 2A diode in series with the coil, will prevent Line Contactor closure if the battery positive and negative connections are reversed.

5.2 Environmental

- 5.2.1.1 Protection - Logic The enclosure is protected to IP66.
1st digit (6) = Protection against dust ingress
2nd digit (6) = Protection against high pressure jets of water in any direction.
5.2.1.2 Protection - Power frame The enclosure is protected to IP55.
1st digit (5) = Limited dust ingress permitted
2nd digit (5) = Protection against low pressure jets of water in any direction. Limited ingress permitted.
5.2.2 Vibration: 6G, 40-200Hz for 1 hour, in x, y and z planes.
5.2.3 Operating Temperature: -30°C to +40°C ambient around controller.
5.2.4 Storage Temperature: -40°C to +70°C.
5.2.5 Humidity: 95% maximum, non-condensing.
5.2.6 Humidity Resistance: No functional defects after controller is left at 60°C and 100% humidity for one hour after freezer use (-30°C minimum). PowerpaK has been Highly Accelerated Life Tested.
5.2.7 HALT: PowerpaK has been Highly Accelerated Life Tested.

5.3 Mechanical

- 5.3.1 Unit size(all units): Length 142mm, Width 142mm, Height 140mm with logic fitted. (Height is 86mm with logic unplugged)
5.3.2 Enclosure: Aluminium die cast base-plate with ABS plastic injection moulded power frame and logic covers.
5.3.3 Power connections: Aluminium vertical power bushes for M8 connection.
5.3.4 Fixings: 4 x M6 clearance holes.
5.3.5 Weight: 1.8Kg

5.4 Logic I/O Specifications

- 5.4.1 **Switch/Digital Inputs:**
Operation: Active-low (The input becomes active when connected to battery negative, otherwise inactive).
Voltage Range: Low (Closed) -1.0 to +1.8 V
High (Open) +4.5 to +150 V (or open-circuit).
Input Impedance: Max. resistance to ground for a 'low' = 500 Ω.
Min. resistance to ground for a 'high' = 2.7 kΩ
Note : negative switch returns must be connected to controller B- terminal and not at battery negative.
5.4.2 **Analogue Inputs:** 0-5V inputs available and 5K potentiometer/3V5-0V inputs available. Fully protected i/ps and threshold settable.
5.4.3 **Supply output:** An unregulated +12V, 5mA power supply is available for supplying Accelerators, speed sensors etc.
5.4.4 **Contactors Drives:** Maximum Current: 2A.
Protection: Drives are protected against direct connection to B+ and B-.
Suppression: Coil suppression built-in.
+ve coil supply Logic variant dependant, see wiring diagrams figs 1-3

connectors in total, 1 for the vehicle connections, 1 for the contactor connections, and 1 for serial communications.

CUSTOMER CONNECTOR & CONTROLLER INTERCONNECT PIN OUT'S

Pin No.	Vehicle & Panel Connector Socket B Pump low I/O Logic. 12 way Molex Connector. 6 Digital i/ps 2 Analog i/ps No Cont. Drives	Vehicle & Panel Connector Socket B Traction Low I/O Logic. 12 way Molex Connector. 6 Digital i/ps 2 Analog i/ps 3 Cont. Drives	Vehicle Connector Socket B Traction Med. I/O Logic. 12 way Molex Connector. 8 Digital i/ps 2 Analog i/ps 1 +12V o/p	Vehicle Connector Socket B Traction High I/O Logic. 16 way Molex Connector. 10 Digital i/ps 2 Analog i/ps 1 +12V o/p
1.	Key sw	Key sw	Key sw	Key sw
2.	Pump sw 3	Fwd sw	Fwd sw	Fwd sw
3.	Pump sw 4	Rev sw	Rev sw	Rev sw
4.	Pump sw 5	FS1/Belly sw	FS1/Belly sw	FS1 sw
5.	See note 3	Seat/Tiller sw	Seat/Tiller sw	Seat sw
6.	See note 3	See note 1	See note 1	See note 1
7.	See note 3	See note 1	See note 1	See note 1
8.	-	Fwd Cont	See note 1	See note 1
9.	-	Rev Cont	See note 2	See note 2
10.	Accel 0V-5V (Pump sw2 / Econ)	Accel/F.Brake/Economy pot /Over Temp 0V-5V	Accel/F.Brake/Economy pot /Over Temp 0V-5V	Accel/F.Brake/Economy pot /Over Temp 0V-5V
11.	Accel 3V5-0V (Pump sw1)	F.Brake/Accel/Economy pot /Over Temp 3V5-0V	Accel/F.Brake/Economy pot /Over Temp 3V5-0V	Accel/F.Brake/Economy pot /Over Temp 3V5-0V
12.	+12V o/p	Regen/Psteer Cont.	+12V o/p	+12V o/p
13.				See note 1
14.				See note 1
15.				-
16.				-

Note 1. The user can configure these inputs to be any of the following:- Speed1, Speed2, Speed3, Inch Fwd (Pins 6,8,13), Inch Rev (Pins 7,14), Pump, Power Steer Trigger, Handbrake, Footbrake, Sideload, Brushes Worn.

Note 2. The user can configure this input to be any of the following:- Speed1, Speed2, Speed3, Inch Rev, Pump, Power Steer Trigger, Handbrake, Footbrake, Sideload, Brushes Worn, Speed Encoder.

Note 3. The user can configure these inputs to be any of the following:- Pump Switch 6, Pump Switch 7, Power Steer Trigger, Pump Inhibit, Motor Temperature, Pump Brushes Worn, Low Oil Pressure.

Pin No.	Panel Connector Socket C Traction Med. I/O Logic. 10 way Molex Connector. 5 Cont. Drives	Panel Connector Socket C Traction High I/O Logic. 12 way Molex Connector. 10 Cont. Drives	Communications Connector Socket A All Logics. 6 way Molex Connector RS232 & CAN
1.	Cont. o/p	Cont. o/p	+ 10V5
2.	Fwd Cont	Fwd Cont	0V
3.	Rev Cont	Rev Cont	N/C
4.	Regen/P.Steer Cont	Regen	+ 10V5
5.	Bypass/F.Weak Cont	P.Steer	CAN High
6.	P.Steer/F.Weak/Pump/Remote LED	Bypass	CAN Low
7.	-	F.Weak	
8.	-	Pump Cont	
9.	-	Remote LED	
10.	-	Any of 2-9	
11.	-	Any of 2-9	
12.	-	-	

6.2.3 **CAN (Controller Area Network) Overview**

CAN is an acronym for Controller Area Network. It is a bus system, meaning that it is a collection of intelligent “nodes” which are connected to the same physical piece of wire. If one node transmits something on the wire, all nodes will receive it (including the one doing the transmitting).

CANbus was developed (in 1984) by Bosch, the German electronics manufacturer, for use in road vehicles. The aim of CANbus is to reduce vehicle wiring, as all electrical functions (such as lights, electric windows, ignition) share the same physical wire. Its emphasis on reliable data transmission has made it popular with manufacturers of industrial equipment and materials handling vehicles.

The main applications for CAN communications are automotive and industrial electronics where high speed, noise immune serial communications are required to work reliably in high vibration and high temperature environments.

SEVCON’S CAN system is defined as CAN 2.0A (Basic CAN, error active) and is implemented using a Philips Semiconductor chip-set with an 80C250 transceiver chip. The PowerpaK CAN protocol sets the baud rate to be 100K bits per second.

CAN is extremely flexible and versatile, allowing multi-master operation in a serial communication network with an almost unlimited number of nodes. Data rates of up to 1 Mbit/s are possible transmitting over distances of up to 40 meters, with a very low probability of undetected errors. CAN is basically a 2-wire twisted-pair differential system with 10V5 and 0v supply rails. Connections are made via a 6way Molex connector.

Presently the CAN bus is used to communicate with the calibrator. It can be used to communicate with a dashboard display and for remote control from a host PC. Long term, communications with auxiliary controllers and equipment will be possible.

E.g. Battery Chargers, Standalone Power Steer Controllers, Controller I/O expanders ...etc. At present it is possible to connect up to 8 pieces of equipment onto the CAN bus.

7 CALIBRATOR AND ADJUSTMENTS

A sophisticated, yet easy to use hand held adjustment unit, called the Calibrator is used to make adjustments to the controller and select configurations. The Calibrator is also used as a diagnostic tool displaying the status of all voltages, currents and temperatures within the controller together with the condition of all the controller's switch and analogue inputs.

The diagram below describes how the Calibrator is used. The left and right arrows move between screens on the same level. The up and down arrows move between levels and the + and - buttons increment or decrement the parameters by the amount indicated in the STEP column of the following tables.

The calibrator can be specified to have various levels of access to certain adjustments.

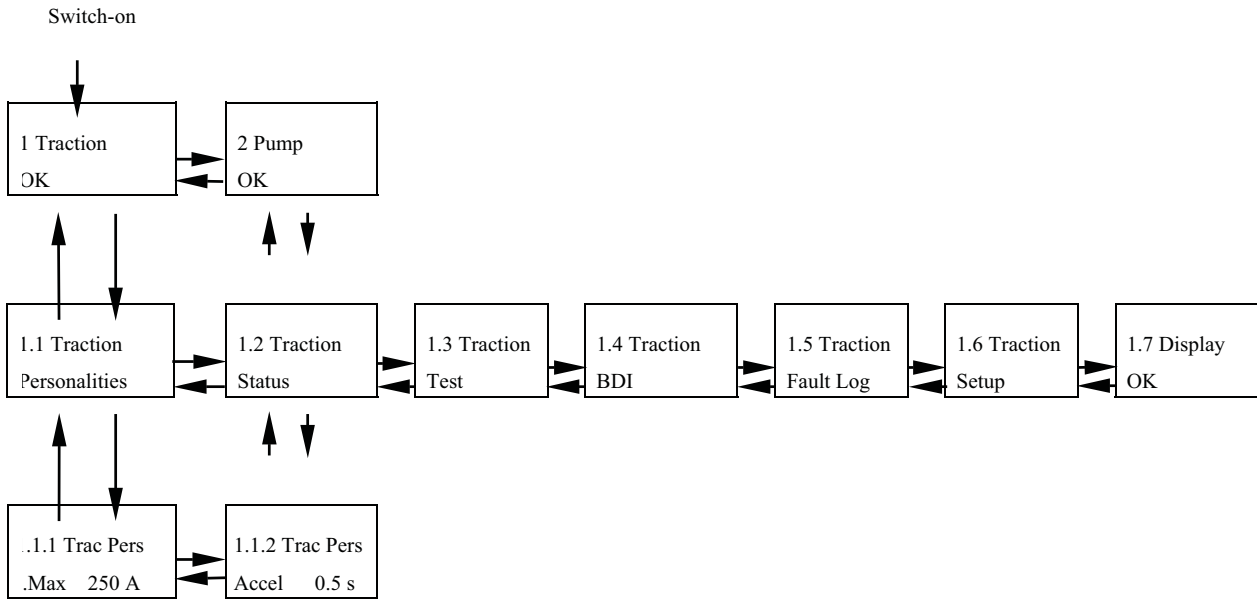
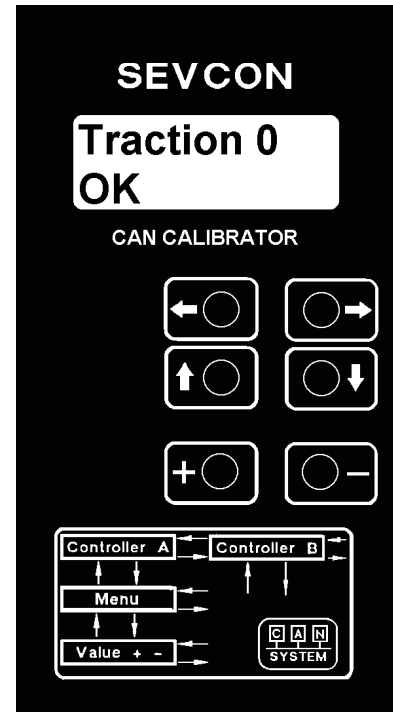

7.1.1 Traction Controller Personalities (Controller Adjustments)

Cal. Ref	Parameter Adjusted (* Note at 80V max current is 600A)	Logic: Low i/o Med i/o Hi i/o	Min adjust (all units)	Max. adjust 300A unit	Max. adjust 450A unit	Max. adjust 650A* unit	Step size all units	Typical Default
1.1.1	Current limit	L,M,H	50 A	300 A	450 A	650 A	10 A	100% A
1.1.2	Acceleration delay	L,M,H	0.1 S	5.0 S	5.0 S	5.0 S	0.1 S	1.5 S
1.1.2a	Current Ramp delay	L,M,H	0.0 S	2.5 S	2.5 S	2.5 S	0.1 S	0.0 S
1.1.3	Deceleration delay	L,M,H	0.1 S	0.5 S	0.5 S	0.5 S	0.1 S	0.3 S
1.1.4	Creep speed	L,M,H	0 %	25 %	25 %	25 %	1.0 %	5.0 %
1.1.5	Direction Plug Current	L,M,H	50 A	370 A	560 A	810 A	10 A	75 % A
1.1.5a	Plug Turn	L,M,H	50 A	370 A	560 A	810 A	10 A	100 A
1.1.6	Neutral Plug Current	L,M,H	10A (0 disables)	370 A	560 A	810 A	10 A	25 % A
1.1.6a	Plugging Threshold	L,M,H	50	255	255	255	1	153/180
1.1.6b	Plug Drop	L,M,H	50 A	370 A	560 A	810 A	10 A	100 A
1.1.7	Footbrake Plug Current	L,M,H	10A (0 disables)	370 A	560 A	810 A	10 A	50 % A
1.1.8	Direction Regen Current	L,M,H	50 A	300 A	450 A	650 A	10 A	200 A
1.1.8a	Speed Limit Braking	M,H	40 A/KPH	300 A	450 A	650 A	10 A	40 A/KPH
1.1.9	Neutral Regen Current	L,M,H	10A (0 disables)	300 A	450 A	650 A	10 A	100 A
1.1.10	Footbrake Regen Current	L,M,H	10A (0 disables)	300 A	450 A	650 A	10 A	150 A
1.1.11	Regen Delay	L,M,H	0mS(0 plug only)	350 ms	350 ms	350 ms	10 ms	160 mS
1.1.12	Maximum speed	L,M,H	0 %	100 %	100 %	100 %	1 %	100 %
1.1.13	Cutback speed 1	L,M,H	0 %	100 %	100 %	100 %	1 %	75 %
1.1.14	Acceleration delay 1	L,M,H	0.1 S	5.0 S	5.0 S	5.0 S	0.1S	1.5 S
1.1.15	Cutback speed 2	L,M,H	0 %	100 %	100 %	100 %	1 %	50 %
1.1.16	Acceleration delay 2	L,M,H	0.1 S	5.0 S	5.0 S	5.0 S	0.1 S	2.0 S
1.1.17	Cutback speed 3	L,M,H	0 %	100 %	100 %	100 %	1 %	25 %
1.1.18	Acceleration delay 3	L,M,H	0.1 S	5.0 S	5.0 S	5.0 S	0.1 S	2.5 S
1.1.19	Inch Speed	L,M,H	0 %	25 %	25 %	25 %	1 %	10 %
1.1.20	Burst Inch Delay	L,M,H	0.1 S	5.0 S	5.0 S	5.0 S	0.1 S	2.0 S
1.1.21	Bypass Over Current	M,H	10 A (0 disables)	450 A	680 A	970 A	10 A	100% A
1.1.22	Bypass Delay	M,H	0.5 S	5.0 S	5.0 S	5.0 S	0.1 S	1.5 S
1.1.23	Field Weak Pull In	M,H	0 A	300 A	450 A	650 A	10 A	100 A
1.1.24	Field Weak Drop Out	M,H	0 A	300 A	450 A	650 A	10 A	200 A
1.1.25	Power Steer Delay	L,M,H	0 S	60 S	60 S	60 S	1.0 S	5.0 S
1.1.26	Seat Switch Delay	L,M,H	0 S	5.0 S	5.0 S	5.0 S	0.1 S	2.0 S
1.1.27	Electric Brake Delay	L,M,H	0S	5.0 S	5.0 S	5.0 S	0.1 S	0 S
1.1.28	Accelerator Zero Level	L,M,H	0 V	5.0 V	5.0 V	5.0 V	0.02 V	
1.1.29	Accelerator Full Level	L,M,H	0 V	5.0 V	5.0 V	5.0 V	0.02 V	
1.1.30	Footbrake Pot ZeroLevel	L,M,H	0 V	5.0 V	5.0 V	5.0 V	0.02 V	
1.1.31	Footbrake Pot Full Level	L,M,H	0 V	5.0 V	5.0 V	5.0 V	0.02 V	
1.1.32	Economy Pot Zero Level	L,M,H	0 V	5.0 V	5.0 V	5.0 V	0.02 V	
1.1.33	Economy Pot Full Level	L,M,H	0 V	5.0 V	5.0 V	5.0 V	0.02 V	
1.1.34	O. Temp Pot Zero Level	L,M,H	0 V	5.0 V	5.0 V	5.0 V	0.02 V	
1.1.35	O. Temp Pot Full Level	L,M,H	0 V	5.0 V	5.0 V	5.0 V	0.02 V	
1.1.36	Speed Limit	M,H	0KPH(0 disables)	60KPH	60KPH	60KPH	1 KPH	0 KPH
1.1.37	Low Voltage Init	L,M,H	14.5 V	48/80 V	48/80 V	48/80 V	0.5V	14.5/43V
1.1.38	Low Voltage Cutback	L,M,H	14.5 V	48/80 V	48/80 V	48/80 V	0.5V	14.5/43V
1.1.39	High Voltage Init	L,M,H	14.5 V	75/100	75/100	75/100	0.5V	70/95.0V
1.1.40	High Voltage Cutback	L,M,H	14.5 V	75/100	75/100	75/100	0.5V	72.5/97.5
1.1.41	Protection Delay	L,M,H	0.1 S	2.5 S	2.5 S	2.5 S	0.1 S	0.1 S

Note 1 : Depending on controller type and configuration some of the above may not be displayed.

Note 2 : pressing the calibrator “down arrow” key from 1.1.2 allows access to 1.1.2a, likewise for 1.1.5a, 1.1.6a and 6b.

Note 3 : pressing the calibrator “down arrow” key from the potentiometer zero and full personalities (1.1.28 to 1.1.35) jumps directly to the associated voltage measurement in the test menu. Pressing this key from the test menu jumps back to the associated zero level personality.

7.1.2 Traction Controller Status Information

Cal. Ref.	Parameter Displayed	Logic Type	Min.Display	Max.Display	Step size	Log Info.
1.2.1	Battery Voltage	L,M,H	0 V	127 V	0.1 V	+
1.2.2	Traction Motor Voltage	L,M,H	0 V	127 V	0.5 V	
1.2.3	Traction Motor Current	L,M,H	0 A	1200 A	6 A	+
1.2.4	Traction Controller Temp.	L,M,H	-30 °C	+225 °C	1 °C	+ -
1.2.5	Traction MOSFET Voltage	L,M,H	0 V	127 V	0.5 V	
1.2.6	Capacitor Voltage	L,M,H	0 V	127 V	0.5 V	
1.2.7	Speed Sensor Indication	L,M,H	0 KPH	60 KPH	1.0 KPH	
1.2.8	Key Switch Hours Count	L,M,H	0 Hrs	65279.9 Hrs	0.1 Hrs	
1.2.9	Traction Pulsing Hours Count	L,M,H	0 Hrs	65279.9 Hrs	0.1 Hrs	
1.2.10	Pump Pulsing Hours Count	L,M,H	0 Hrs	65279.9 Hrs	0.1 Hrs	
-	Service Log Reset	L,M,H	press + followed by - to reset service log			

Note1 : Log Info shows where the + and - keys can be used to access the service max and min data.

7.1.3 Traction Controller Test Information

Cal. Ref.	Input Displayed	Logic Type	Min. Display	Max.Display	Step Size
1.3.1	Accelerator % Range	L,M,H	0 %	100 %	1 %
1.3.2	Accelerator Voltage Range	L,M,H	0.0 V	5.0 V	0.02 V
1.3.3	Footbrake Pot. % Range	L,M,H	0 %	100 %	1 %
1.3.4	Footbrake Pot. Voltage Range	L,M,H	0.0 V	5.0 V	0.02 V
1.3.5	Economy Pot. % Range	L,M,H	0 %	100 %	1 %
1.3.6	Economy Pot. Voltage Range	L,M,H	0.0 V	5.0 V	0.02 V
1.3.7	O. Temp Pot. % Range	L,M,H	0 %	100 %	1 %
1.3.8	O. Temp Pot. Voltage Range	L,M,H	0.0 V	5.0 V	0.02 V
1.3.9	Forward	Switch	Open	Closed	-
1.3.10	Reverse	Switch	Open	Closed	-
1.3.11	FS1	Switch	Open	Closed	-
1.3.12	Belly	Switch	Open	Closed	-
1.3.13	Seat	Switch	Open	Closed	-
1.3.14	Tiller	Switch	Open	Closed	-
1.3.15	Speed Cutback 1	Switch	Open	Closed	-
1.3.16	Speed Cutback 2	Switch	Open	Closed	-
1.3.17	Speed Cutback 3	Switch	Open	Closed	-
1.3.18	Inch Forward	Switch	Open	Closed	-
1.3.19	Inch Reverse	Switch	Open	Closed	-
1.3.20	Handbrake	Switch	Open	Closed	-
1.3.21	Footbrake	Switch	Open	Closed	-
1.3.22	Power Steer Trigger Input	Switch	Open	Closed	-
1.3.23	Pump Contactor Trigger	Switch	Open	Closed	-
1.3.24	Speed Limit	Switch	Open	Closed	-
1.3.25	Sideloading	Switch	Open	Closed	-
1.3.26	Speed Encoder	Switch	Open	Closed	-
1.3.27	Brushes Worn	Switch	Open	Closed	-
1.3.28	Software Version/Revision	L,M,H	000.00	999.99	-
1.3.29	Controller Serial Number	L,M,H	00000000	99999999	-

Note 1: As with the personalities, only relevant switch tests will be shown determined by configuration.

Note 2: An asterisk will appear on menu 1.3.2 when FS1 is closed.

7.1.4 BDI Adjustments (if enabled in setup menu)

Cal. Ref.	Parameter Adjusted/Displayed	Logic Type	Min Setting	Max. Setting	Step Size.	Default
1.4.1	Xxx % Charge remaining	L,M,H,P	display only			
1.4.2	Battery Volt xx V	L,M,H,P	24 V	96 V	2 V	Nominal V
1.4.3	Reset x.xx V/Cell	L,M,H,P	2.00 V/Cell	2.50 V/Cell	0.01 V/Cell	2.09V
1.4.4	Empty x.xx V/Cell	L,M,H,P	1.50 V/Cell	1.99 V/Cell	0.01 V/Cell	1.73V
1.4.5	Warning xx %	L,M,H,P	0 %	90%	1.0 %	30%

1.4.6	Cutout xx %	L,M,H,P	0 %	90%	1.0 %	0%
-------	-------------	---------	-----	-----	-------	----

-7.1.5 Fault Log

Can be disabled via setup menu. See section 9 for more details.

7.1.6 Traction Controller Setup Menu (Enables/Disables features)

Cal.Ref	Feature	Logic Type	Options
1.6.1	Contacting Chopping	L,M,H	24 V / On / Off
1.6.2	Accelerator Type	L,M,H	Linear / Curved / 2* Slope/ Crawl
1.6.3	BDI	L,M,H	On / Off
1.6.4	Power Steer Trigger	L,M,H	None to FS1+Dir+Brake+Seat
1.6.5	Economy Cuts Traction Current	L,M,H	On / Off
1.6.6	Bypass in Current Limit	M,H	On / Off
1.6.7	SRO	L,M,H	On / Off
1.6.8	Braking	L,M,H	Proportional / Constant
1.6.9	Plugging Style	L,M,H	Constant Current / Fixed Percentage
1.6.10	Ride-on / Walkie truck	L,M,H	Ride-On / Walkie
1.6.11	Tiller switch	L,M,H	On / Off
1.6.12	Digital i/p 5 config (Skt B pin 6)	L,M,H	Inch Fwd (only Pins 6 & 8) / Inch Rev (only Pins 7 & 9) / Pump / Pst Trig / Handbrake / Footbrake / Speed cutback 1 / Speed cutback 2 / Speed cutback 3 / Speed Limit / Sideload / Brushes Worn / Speed Probe(only Pin 9)
1.6.13	Digital i/p 6 config (Skt B pin 7)	L,M,H	
1.6.14	Digital i/p 7 config (Skt B pin 8)	M,H	
1.6.15	Digital i/p 8 config (Skt B pin 9)	M,H	
1.6.16	Analog i/p 1 config (Skt B pin 10)	L,M,H	Accelerator / Footbrake / Economy / O. Temp
1.6.17	Analog i/p 2 config (Skt B pin 11)	L,M,H	Accelerator / Footbrake / Economy / O. Temp
1.6.18	Digital i/p 9 config (Skt B pin 13)	H	Inch Fwd (only Pin 13) / Inch Rev (only Pin 14) / Pump / Pst Trig / Handbrake / Speed cutbacks 1,2,3
1.6.19	Digital i/p 10 config (Skt B pin 14)	H	
1.6.20	Contacting 3 (Skt B pin 12 Low I/O) config . (Skt C pin 4 Med/Hi I/O)	L,M	Low I/O Logic - P.Steer /Regen/Electric Brake Med I/O Logic - Regen /P.Steer High I/O Logic - Regen only
1.6.21	Contacting 4 config (Skt C pin 5)	M	Bypass / F.Weak
1.6.22	Contacting 5 config (Skt C pin 6)	M	F.Weak / P.Str / Pump / Remote LED / BDI Cut / E. Brake
1.6.23	Contacting 9 config (Skt C pin 10)	H	Forward / Reverse / Regen / P.Str / Bypass / F.Weak / Pump / Remote LED / BDI Cut / E. Brake
1.6.24	Contacting 10 config (Skt C pin 11)	H	Forward / Reverse / Regen / P.Str / Bypass / F.Weak / Pump / Remote LED / BDI Cut / E. Brake
1.6.25	Seat Switch Cuts Pump	M,H	On / Off
1.6.26	Fault Log	L,M,H	On / Off
1.6.27	Service Log	L,M,H	On / Off
1.6.28	Probe Speed	M,H	High / Low. Select High for Encoders which have a maximum frequency of 100Hz to 2000Hz. Select Low for Encoders which have a maximum frequency of 10Hz to 200Hz.
1.6.29	Full Speed	M,H	5 to 60 KPH in 1 KPH steps default 20
1.6.30	Probe Frequency	M,H	If Probe Speed is set to High, then Probe Frequency has the range 100 to 2000Hz in 10 Hz steps (default 1000). If Probe Speed is set to Low, then Probe Frequency has the range 10 to 200Hz in 1 Hz steps (default 100).
1.6.32	Canbus Mode	L,M,H	Standalone / CAN Master
1.6.33	Switch Limits Speed	L,M,H	On/Off
1.6.34	Inch E-Brakes	L,M,H	On/Off

Note 1: Changes only take effect after a key-switch recycle

7.2.1 Pump Controller Personalities (Controller Adjustments)

Cal. Ref	Parameter Adjusted	Logic Type	Min adjust (all units)	Max.adjust 450 A unit	Max.adjust 650 A unit	Step size (all units)	Typical Default
2.1.1	Current Limit	P	50 A	450 A	650 A	10 A	100% A

2.1.2	Ramp Up Delay	P	0.1 S	5.0 S	5.0 S	0.1 S	0.5 S
2.1.3	Ramp Down Delay	P	0.1 S	0.5 S	0.5 S	0.1 S	0.3 S
2.1.4	Creep Speed	P	0 %	25 %	25 %	1.0 %	5.0 %
2.1.5	Pump Speed 1	P	0 % (0=inhibit)	100 %	100 %	1.0 %	100 %
2.1.6	Pump Compensation 1	P	1 % (0 disables)	200 %	200 %	1.0 %	0 %
2.1.7	Pump Speed 2	P	0 % (0=inhibit)	100 %	100 %	1.0 %	80 %
2.1.8	Pump Compensation 2	P	1 % (0 disables)	200 %	200 %	1.0 %	0%
2.1.9	Pump Speed 3	P	0 %	100 %	100 %	1.0 %	60 %
2.1.10	Pump Compensation 3	P	1 % (0 disables)	200 %	200 %	1.0 %	0 %
2.1.11	Pump Speed 4	P	0 %	100 %	100 %	1.0 %	50 %
2.1.12	Pump Compensation 4	P	1 % (0 disables)	200 %	200 %	1.0 %	0 %
2.1.13	Pump Speed 5	P	0 %	100 %	100 %	1.0 %	40 %
2.1.14	Speed 5 (Priority/Additive)	P	priority	additive	additive	-	priority
2.1.15	Pump Speed 6	P	0 %	100 %	100 %	1.0 %	30 %
2.1.16	Speed 6 (Priority/Additive)	P	priority	additive	additive	-	priority
2.1.17	Pump Speed 7	P	0 %	100 %	100 %	1.0 %	25 %
2.1.18	Speed 7 (Priority/Additive)	P	priority	additive	additive	-	priority
2.1.19	Power Steer Speed	P	0 %	100 %	100 %	1.0 %	15 %
2.1.20	Power Steer Compensation	P	1 % (0 disables)	200 %	200 %	1.0 %	0 %
2.1.21	Power Steer Ramp Up Delay	P	0.1 S	5.0 S	5.0 S	0.1 S	0.3 S
2.1.22	Power Steer Ramp Down Delay	P	0.1 S	0.5 S	0.5 S	0.1 S	0.3 S
2.1.23	Power Steer Delay	P	0 S	60 S	60 S	1 S	2 S
2.1.24	Seat Switch Delay	P	0 S	5 S	5 S	0.1 S	2 S
2.1.25	Accelerator Zero Level	P	0.0 V	5.0 V	5.0 V	0.02 V	
2.1.26	Accelerator Full Level	P	0.0 V	5.0 V	5.0 V	0.02 V	
2.1.27	Accelerator 2 Zero Level	P	0.0 V	5.0 V	5.0 V	0.02 V	
2.1.28	Accelerator 2 Full Level	P	0.0 V	5.0 V	5.0 V	0.02 V	
2.1.29	Low Voltage Init	P	14.5 V	48V for 24-48Vunits, 80V for 72-80V		14.5/43V	
2.1.30	Low Voltage Cutback	P	14.5 V	48V for 24-48Vunits, 80V for 72-80V		14.5/43V	
2.1.31	High Voltage Init	P	14.5 V	75V for 24-48Vunits, 100V for 72-80V		70/97.5V	
2.1.32	High Voltage Cutback	P	14.5 V	75V for 24-48Vunits, 100V for 72-80V		72.5/97.5	
2.1.33	Protection Delay	P	0.1 S	2.5 S	2.5 S	0.1 S	0.1 S

7.2.2 Pump Controller Status Information

Cal. Ref	Parameter Displayed	Logic Type	Min. Display (all units)	Max.Display (all units)	Step size (all units)	Log Info.	
2.2.1	Battery Voltage	P	0 V	127 V	0.5 V	+	
2.2.2	Pump Motor Voltage	P	0 V	127 V	1 V		
2.2.3	Pump Motor Current	P	0 A	1200 A	6 A	+	
2.2.4	Pump MOSFET Voltage	P	0 V	127 V	0.5 V		
2.2.5	Pump Controller Temp.	P	-30 °C	+225 °C	1 °C	+ -	
2.2.6	Key Switch Hours Count	P	0 Hrs	65279.9 Hrs	0.1 Hrs		
2.2.7	Pump Pulsing Hours Count	P	0 Hrs	65279.9 Hrs	0.1 Hrs		
-	Service Log Reset	P	press + followed by - to reset service log				

Note : Log Info shows where the + and - keys can be used to access the service max and min data.

7.2.3 Pump Controller Test Information

Cal .Ref.	Input Displayed	Logic Type	Min.Display (all units)	Max.Display (all units)	Step size (all units)
2.3.1	Accelerator 1 % Range	P	0 %	100 %	1 %
2.3.2	Accelerator 1 Voltage Range	P	0.0 V	5.0 V	0.1 V
2.3.3	Accelerator 2 % Range	P	0 %	100 %	1 %
2.3.4	Accelerator 2 Voltage Range	P	0.0 V	5.0 V	0.1 V
2.3.5	Pump Switch 3	P	Open	Closed	-
2.3.6	Pump Switch 4	P	Open	Closed	-
2.3.7	Pump Switch 5	P	Open	Closed	-
2.3.8	Pump Switch 6	P	Open	Closed	-
2.3.9	Pump Switch 7	P	Open	Closed	-

2.3.10	Power Steer Trigger	P	Open	Closed	-
2.3.11	Inhibit	P	Open	Closed	-
2.3.12	Motor Temperature	P	Open	Closed	-
2.3.13	Brushes Worn	P	Open	Closed	-
2.3.14	Low Oil	P	Open	Closed	-
2.3.15	Software Version/Revision	P	000.00	999.99	-
2.3.16	Controller Serial Number	P	00000000	99999999	-

Note : pressing the calibrator “down arrow” key from 2.3.11 allows access to 2.3.11a.

7.2.4 Pump BDI (as Traction 7.1.4)

7.2.5 Pump Fault Log (as Traction 7.1.5)

7.2.6 Pump Setup Menu Enables/Disables features

Cal Ref.	Feature	Logic Type	Options
2.6.1	CANbus Mode	P	Standalone / CAN Slave
2.6.2	Accelerator Type	P	Linear / Curved / 2 *Slope / Crawl
2.6.3	Accelerator 2	P	Lift / Economy / O. Temp
2.6.4	BDI	P	On / Off
2.6.5	Fault Log	P	On / Off
2.6.6	Service Log	P	On / Off
2.6.7	Seat and Pump	P	On / Off
2.6.8	Digital i/p 4 config (Skt B pin 5)	P	P.Switch 6 / P.Switch 7 / P. Steer / Inhibit / Motor Temp / Brush Worn / Low Oil
2.6.9	Digital i/p 5 config (Skt B pin 6)		
2.6.10	Digital i/p 6 config (Skt B pin 7)	P	
2.6.11	Power Steer Active Sense	P	Open / Closed

Note: changes only take effect after a key-switch recycle.

7.3.1 Traction and Pump adjustment descriptions

Adjustment	Logic type	Description (T=Affects traction, P=Affects Pump)
Current Limit	L,M,H,P	Maximum allowable motor current.
Acceleration Delay	L,M,H,P	Time taken to ramp up from 0 to 100% on.
Current Ramp Delay	L,M,H	Time taken to ramp up current in plugging and drive.
Deceleration Delay	L,M,H,P	Time taken to ramp down from 100% to 0% on.
Creep Speed	L,M,H,P	Minimum applied % on when drive first selected. Only PS1 on pump
Dir.Brake Current (Plug)	L,M,H	Maximum Plug braking current during direction switch change.
Plug Turn Current (Plug)	L,M,H	Current at which braking ends and drive starts. (Fixed percentage only)
Neut.Brake Current (Plug)	L,M,H	Maximum Plug braking current in neutral.
Plugging Threshold (Plug)	L,M,H	Plug to Drive threshold. Higher numbers mean earlier plug exit
Plug Drop Current (Plug)	L,M,H	Current at which neutral braking ends. (Fixed percentage only)
Footbrake Current (Plug)	L,M,H	Maximum Plug braking current in neutral when F.brake switch active.
Dir.Brake Current (Reg)	L,M,H	Maximum Regen braking current during direction switch change.
Neut.Brake Current (Reg)	L,M,H	Maximum Regen braking current in neutral.
Footbrake Current (Reg)	L,M,H	Maximum Regen braking current in neutral when F.brake switch active.
Speed Brake Current	M,H	Maximum Braking current when speed limit braking.
Regen Delay (Reg)	L,M,H	Used to minimise delays for unsuccessful Regen attempts at low speeds. Higher numbers give Regen at lower speeds. 0 forces plugging only.
Maximum Speed	L,M,H	Maximum allowable % on.
Cutback Speeds 1, 2 & 3	L,M,H	Maximum allowable % on when cutback switches active.
Accel. Delay 1, 2 & 3	L,M,H	Independently adjustable acceleration delays during speed cutbacks.

Inch Speed	L,M,H	Maximum allowable % on during inching operation.
Burst Inch Delay	L,M,H	Timer to allow inching for a set period only.
Bypass Over Current	M,H	Maximum allowable current in Bypass before contactor opens.
Bypass Delay	M,H	Time for Bypass contactor to close after 100% on reached
F.W. Pull In Current	M,H	F.Weak. contactor allowed to pull in at currents < pull in level.
F.W Drop out Current	M,H	F.Weak. contactor will drop out at currents > drop out level.
Power Steer Delay	L,M,H	Delay after power steer trigger removed until contactor opens.
Seat Switch Delay	L,M,H,P	Delay after seat switch opens until pulsing is inhibited.
Zero Levels	L,M,H,P	Used to select minimum voltage input level for function. E.g. an Accel Zero level=0.5V means pulsing begins at 0.5V I/P
Full Levels	L,M,H,P	Used to select maximum voltage input level for function, E.g. an Accel Full Level of 4.0v means 100% pulsing is reached at 4V I/P
Speed Limit	M,H	Used with external speed sensor to provide speed limit feature.
Low Voltage Init	L,M,H,P	Voltage at which controllers starts reducing the max available current limit to help reduce voltage drops
Low Voltage Cutback	L,M,H,P	Voltage at which current limit is reduced to 0
High Voltage Init	L,M,H,P	Voltage at which controller changes from Regen braking to Plug braking to help prevent high generated voltages damaging the battery or controller.
High Voltage Cutback	L,M,H,P	Voltage at which contactors will open, to prevent high voltage damage.
Battery Protection	L,M,H,P	Voltages below this level cause a battery low 7 flash fault
Protection Delay	L,M,H,P	Length of time the voltage can fall below the Battery Protection level for, before a fault is indicated. This helps prevent spikes tripping a low batt fault
Pump Speeds 1-7	P	Maximum allowable % on's when respective switch active
Power Steer Speed	P	As above, but for Power Steer speed.
Pump Comp. 1-4	P	Set-up compensation by adjusting the relevant pump speed to give the required minimum no load speed, then set the associated compensation adjustment to give the same speed under full load conditions
Power Steer Comp.	P	As above but for Power Steer speed compensation.
Power Steer Ramp up	P	Independent acceleration delay for power steer function.
P. Steer Ramp down	P	As above but deceleration delay.
Speed 5, 6 & 7 Priority/Additive	P	Lower numbers have priority over higher numbers. Additive is where the speed 5, 6 or 7 is added to lower numbered switches.
Electric Brake Delay	L,M,H	Used to specify a variable time delay between the power steer trigger becoming inactive and the electric brake contactor opening (brake on).

7.3.2 Setup Menu Descriptions

Setup menu Option	Logic Type	Description
Contactor Chopping	L,M,H	24V/On/Off - Set to 24V to obtain 24V across coils when a lamp is also being driven, On when just contactor coils are being driven and Off when battery voltage contactor coils are used.
Accelerator type	L,M,H, P	Linear/Curved/2*slope/Crawl - Set to Linear for a straight line accelerator characteristic, Curved for more low speed manoeuvrability, 2*Slope for a balance between Linear and Curved, and Crawl for a very shallow low speed manoeuvrability curve. See graph 2 appendix.
BDI	L,M,H, P	On/Off - On enables the BDI (Battery Discharge Indicator) and any warning/cut-out settings, Off disables the BDI feature and removes the BDI setup menu display.
Power Steer Trigger	L,M,H	None/FS1/Dir/F+D/Brake/F+B/D+B/F+D+B/Seat/F+S/D+S/F+D+S/B+S/F+B+S/D+B+S/F+D+B+S – These are the various triggers for power steer activation, FS1 or F = FS1 switch, Dir or D = Direction switch, Brake or B = Foot brake and Seat or S = Seat switch . e.g. setting to FS1 will trigger the power steer delay only when FS1 is close., whilst setting to F+D+B will trigger the delay when either FS1 or Direction or the Brake switches are closed.
Economy cuts traction current	L,M,H	On/Off - set to On for current limit to be reduced during economy or Off for just the standard acceleration delay increase.
Accelerator 2 Type	P	Lift is pump accel 2 or Economy for use as economy input (current limit reduced) or O. Temp for use as overtemperature sensor input (current limit reduced)
Bypass in current limit	M,H	On/Off - On =Bypass at max %on and current limit, Off = just Bypass at max %on.

SRO	L,M,H	On/Off - On = SRO enabled, Off = SRO disabled
Braking	L,M,H	Prop/Const - Prop = Direction braking level is proportional to accelerator position, Const = Direction braking is constant level.
Plugging Style	L,M,H	Constant Current = fixed current level plugging, Fixed Percentage plugging
Ride-on / Walkie truck	L,M	Ride-on / Walkie – Ride-on = Skt B pin 4 is FS1 input, pin 5 is Seat sw i/p Walkie = Skt B pin 4 is Belly sw input, pin 5 is tiller sw i/pt
Tiller switch	L,M	On/Off - On =Tiller switch must be wired in, Off = leave Skt B pin 5 un connected
Digital Input Configuring	L,M,H	Inch Fwd/Inch Rev/Pump/Speed 1 cutback/Speed 2 cutback/Speed 3 cutback /Handbrake/Footbrake/Pst. Trig/ Speed Limit/Sideloading/Brushes Worn/ Speed Encoder
Digital Input Configuring	P	P.Switch 6 / P.Switch 7 / P. Steer / Inhibit / Motor Temp / Brush Worn / Low Oil
Analog Input Configuring	L,M,H	None/Accel/Footbrake Pot/Economy pot/Over Temp pot Skt B pins 10 & 11 analog inputs can be configured to perform the above input functions.
Contactors Output 3-6 configuring.	L,M,H	Forward/Reverse/P.Steer/Regen/Bypass/F.Weak/Pump/Remote LED / BDI Cut / E. Brake Skt B pin 12 (Low I/O logics only) and Skt C pins 4,5,6 (Med & High I/O Logics) and Skt C pins 9 & 10 (High I/O logic only) can be configured to perform some of the above Contactor output functions.
Seat switch cuts pump	M,H	On/Off - On = Seat switch cuts Traction and Pump, Off = just Trac.
Seat switch cuts pump	P	On/Off - On = Seat switch cuts just Pump, Off = disabled
Fault Log	L,M,H, P	On/Off - On = Fault Log enabled, Off = Disabled and no display.
Service Log	L,M,H, P	On/Off - On = Service Log enabled, Off = Disabled and no display.
Canbus Mode	L,M,H, P	Standalone – standalone operation, CAN Master – Canbus master for controlling display (L,M,H only), CAN Slave – Canbus slave (P only)
Probe Speed, Full Speed and Probe Frequency	M,H	These setup items are used to set up an encoder in the system. The Probe Speed item is used to select the frequency range of the encoder.. High Probe Speeds refer to Encoders in the range 100Hz to 2000Hz and usually applies to encoders mounted on the Motor, Low Probe Speeds refer to Encoders in the range 10Hz to 200Hz and usually applies to encoders mounted on the Axle or Wheel. The Full Speed and Probe Frequency items are used to calibrate the encoder. To set these up, find the output frequency of the Probe at the vehicles top speed. For example, if a vehicle had an encoder mounted on the motor's rotor and the encoder gave an output frequency of 1500Hz at a top speed of 20KPH, then Probe Speed is set to High, Probe Frequency is set to 1500Hz and Full Speed is set to 20KPH.
Switch Limits Speed	L,M,H	On/Off - On = speed limit applied if speed limit switch input is active, if speed limit switch is inactive no speed limit is applied, Off = speed limit applied regardless of switch.
Power Steer Active Sense	P	Open/Close - power steer is on when the digital input configured as P.Steer matches this setup state, otherwise the power steer is off (unless internally triggered)

7.3.3 BDI adjustment descriptions

BDI Adjustment	Logic Type	Description
Charge remaining	L,M,H	Displays remaining battery charge. Display only, no adjustments can be made.
Battery Voltage	L,M,H	Adjustment used to enter the nominal battery voltage
Reset Volts/Cell	L,M,H	Sets the voltage at which the BDI resets to 100% at power up. E.g. the BDI will reset to 100% on a 48V system, with the reset adjustment set to 2.20 Volts per cell, if the battery voltage is above 52.8V. $(48V/2)*2.20V$
Empty Volts/Cell	L,M,H	Sets the voltage at which the BDI indicates the battery is fully discharged E.g. the BDI will eventually show 0% on a 48V system, with the empty adjustment set to 1.60 Volts per cell, if the battery voltage is below 38.4V. $(48V/2)*1.60V$
Warning Level %	L,M,H	Sets the discharged level at which the warning threshold is reached, at which point the remaining lit segments flash.
Cutout Level %	L,M,H	Sets the discharged level at which the cut-out threshold is reached, at which point all the segments flash together and the cut-out action, Pump cut-out and Traction speed 2 limit initiated.

8 DIAGNOSTICS

Traction and Pump Fault Messages and LED status/number of flashes

	Calibrator Message	Standard Display	Full Feature Display	Led	Description and how to clear	Check...
0	OK (lowest priority)			on	Traction operational and OK.	No action required.
1	Testing...	Run Tests		on	Only displayed briefly at power up.	No action required.
2	Trac Brush	Trac Brush	TRAC BRUSHES	on	Traction brushes worn.	Check brushes.
2	Pump Brush	Pump Brush	PUMP BRUSHES	on	Pump brushes worn.	Check brushes.
3	Pump Overtemp	Pump Hot	PUMP HOT	on	Pump over temperature.	Allow controller to cool.
4	Oil Fault	Oil Fault	OIL LOW	on	Oil pressure low.	Check oil.
5	BDI Cutout	BDI Cut	BDI CUT OUT	7F	BDI enabled and cut-out action initiated.	Battery charged.
6	Thermal Cutback	Over Temp.	TRAC HOT	8F	Traction heatsink above 75°C. Allow controller to cool.	Heatsinking, Mounting, Surfaces clean, fan req.
6	Thermal Cutback	Over Temp.	PUMP HOT	8F	Pump heatsink above 75°C. Allow controller to cool.	Heatsinking, Mounting, Surfaces clean, fan req.
7	Speed Probe	Speed Probe	SPEED PROBE	6F	Speed limit feature enabled & wire off.	Probe connections.
8	Accel. Fault	Accel Fault	ACCEL FAULT	6F	Accel. pedal pressed at power up, or wire off. Recycle FS1 and Direction.	Accel wiring. Accel Zero & Full Personalities.
9	Contacto r o/c	Cont o/c	CONTACT FAULT	4F	Contacto r has bad contact or didn't close, motor o/c. Recycle FS1 & Dir.	Coil wiring, power wiring, motor o/c.
10	Contacto r s/c	Cont s/c	CONTACT FAULT	4F	Contacto r didn't open or is welded. Recycle FS1 and Direction switch.	Welded tips, particles in tips, wiring.
11	Sequence Fault	Seq. Fault	SEQ FAULT	2F	Direction or FS1 switch at power up. Recycle Direction FS1 or both.	Dir and FS1 in neutral and Dir/FS1 wiring.
12	2 Dir. Fault	2 Dir Fault	2 DIR FAULT	2F	Two directions selected together. Recycle both Directions and FS1.	Direction switch wiring.
13	SRO Fault	SRO Fault	SRO FAULT	2F	Dir. switch selected > 2 seconds after FS1. Recycle FS1 and Dir.	Dir first then FS1, FS1 and Dir. switch wiring.
14	Seat Fault	Seat Fault	SEAT FAULT	2F	Drive selected and no seat sw. Recycle Dir and FS1 switch	Seat switch, closed, seat wiring.
15	Inch Fault	Inch Fault	INCH FAULT	2F	Inch switch at power up , both inch switches selected or inching attempted with seat switch or Dir/FS1 selected. Recycle inch switches.	Inch switch in neutral at power up ,only 1 selected, Seat/Dir/FS1 switches open.
16	Battery High	Bat. High	BATTERY HIGH	7F	Battery > High battery personality. Recycle FS1 or Direction switch	Correct battery voltage. Loose or missing B+ to controller.
17	Battery Low	Bat. Low	BATTERY LOW	7F	Battery < Low battery personality. Recycle FS1 or Direction switch	Correct battery voltage, Discharged battery.
18	Pers Error	Pers Error	PERS ERROR	1F	Personalities out of range at power up.	Reset personalities out of range (shown as ----.-).
19	CRC error	CRC Error	CRC ERROR	1F	One or more personalities have been corrupted.	Check all personalities then recycle keyswitch.
20	Coil s/c	Coil s/c	COIL FAIL	9F	A contacto r coil s/c or miswired. Recycle Keyswitch	coil s/c, Drive connected directly to B+ve, wiring.
21	Mosfet s/c	FET s/c	MOSFET FAIL	3F	Bypass contacto r s/c or MOSFET s/c Recycle FS1 or Direction	A / P /B- power wiring, MOSFETs s/c.
22	Canbus Fault	Canbus Fault	CAN FAULT	12 FF	Can connection between controllers has been disconnected	Can connection between controllers.

23	Various internal controller power up messages (highest priority)	FAIL	FAIL	off	If any of these message are displayed then the controller has failed one of its internal power up checks.	Contact Sevcon.
----	--	------	------	-----	---	-----------------

9 SERVICE AND FAULT LOGS (All Logics)

The Service and Fault Logs have been incorporated to allow end users and service personnel to inspect and note the controller's performance and fault history. Utilising the controller's existing Status measurements and Diagnostics capabilities, information (such as the maximum temperature the controller has operated at or the number and type of faults that have been detected) can be stored in non-volatile memory and presented at a later date. Both the Service and Fault logs can be selected/deselected via the setup menu on the calibrator, and when selected can be cleared at any time to start recording new data.

9.1 Service Log

Service information is available in the Traction and Pump Status menus, where holding down the '+' key shows the maximum value of the current item, and holding down the '-' key shows the minimum value. The following items are logged:

- Maximum Battery Voltage
- Maximum Motor Current
- Maximum Controller Temperature and Minimum Controller Temperature.

To clear the log, access the "Service Log + to reset log" message at the end of the Status menu, and follow the prompts. The service log can be enabled and disabled in the Setup menu.

9.2 Fault Log

The Fault log is available at location 1.5 on the calibrator. Faults are grouped together by "LED flash fault"; the types of flash fault and whether each is logged is shown below. Generally faults that can occur during normal operation e.g. a 2 flash driver procedure error or an 8 flash thermal cutback indication, are not logged.

- | | | |
|------------------|------------|--|
| - LED off faults | Logged | (Internal controller power up check faults) |
| - 1 flash faults | Logged | (Personality/CRC faults) |
| - 2 flash faults | Not Logged | (Driver procedure/sequence/wiring type faults) |
| - 3 flash faults | Logged | (MOSFET/Bypass wiring type faults) |
| - 4 flash faults | Logged | (Contactor o/c or s/c or wiring type faults) |
| - 5 flash faults | Not Logged | (Not used) |
| - 6 flash faults | Not Logged | (Potentiometer wire off type faults) |
| - 7 flash faults | Logged | (Battery low or high faults) |
| - 8 flash faults | Not Logged | (Thermal cutback faults) |
| - 9 flash faults | Logged | (Contactor coil s/c type faults) |

Each of the above logged categories contains - The total number of faults of this type, the Key hours count of the most recent fault and a text description of the fault. An example of how the Fault Log information is presented is shown below:

12*04F 12345.6hr Contactor o/c

This display shows that 12 4-Flash faults have occurred and been logged, the most recent at 12345.6 Key hours and it was a Contactor o/c fault.

Once into the fault log menu, the left and right arrows are used to view any faults stored and at the end of the list a "Fault Log + to reset log" message is shown, where the Fault Log can be reset in a similar way to the service log. The Fault Log can be enabled and disabled in the setup menu.

10 CONTROLLER OPERATION AND FEATURE DESCRIPTIONS

10.1 TRACTION OPERATION - Applicable to all Traction logics unless otherwise specified

- 10.1.1 **Start Up Sequence** - At keyswitch on, the Direction and FS1 switches must be in the neutral condition simultaneously at least once before drive can be selected. This is a safety feature to help prevent unexpected movement immediately after power up.
- 10.1.2 **SRO** (Static return to off)- This feature is optional in the setup menu and when specified, forces the following sequences of switch inputs to be followed before drive is allowed: Keyswitch-Direction-FS1 or Keyswitch-FS1-Direction (within 2 seconds of FS1) . Any other sequence will not allow drive. Drive will be inhibited if FS1 is active for more than 2 seconds with no direction selected. In this case the FS1 will need to be recycled.
- 10.1.3 **Seat Switch** - If the seat switch is opened and the seat switch timer has timed out during drive the controller will stop pulsing and a seat fault will be indicated. Before drive can be restarted the seat switch must be closed, and FS1 and the direction switch must be recycled through neutral. Note the start sequence for drive requires that the seat switch is closed and both the direction and FS1 switches are in the neutral position simultaneously before drive can be initiated. The time period is programmed by means of the Calibrator (Seat Switch Delay). As a setup menu option the seat switch can also inhibit pump operation if required. There are also additional seat switch start up sequences available as options, although the above described SEVCON standard is recommended.
- 10.1.4 **Belly Switch** - (Not available on High I/O logic) - A Belly Switch function is available when the controller is used on a walkie type truck. The feature can be enabled in the setup menu. See this section and wiring diagrams for additional information. Basic operation is as follows:-
- Truck moving in Reverse and activating the Belly Switch, accelerator in reverse position:-
- a) The contactors change direction to forward drive (this initiates plug braking).
 - b) 150% maximum plugging is applied for a maximum of 1.5 seconds, when it will then revert to maximum plugging.
 - c) The vehicle will accelerate at full speed along the accelerator curve.
 - d) All drive will cease 1.5 seconds from the start of (c) above.
 - e) The controller will wait for neutral to be selected before drive will operate. If the Belly switch is pressed again however, action as at c) above.
- Accelerator in Neutral:- As above
- Accelerator in Forward position :- Start at c) above
- Truck moving in Forward and activating the Belly Switch, accelerator in forward position:-
- Accelerator in Forward position :- No effect
- Accelerator in Reverse position :- Belly switch closed, truck drives as per start of c) above.
- 10.1.4 **Handbrake Switch** (Not available on Low I/O logic) - An input is provided for the connection of a handbrake switch, which if operated will disable traction pulsing but leave the drive related contactors in position to effect a minimum roll back hill start when drive is selected and the handbrake is released.
- 10.1.6 **Deceleration Delay** - This is an adjustable delay to ramp down the pulsing from 100% on to 0% on, and can be used to limit the inherent truck lurch when acceleration is interrupted. When neutral is selected, contactors are only opened when the % on has ramped down to 0.
- 10.1.7 **Creep** - The Creep speed is adjustable and is used to select a minimum pulsing level as soon as drive is requested, to minimise delays and dead-bands. The motor voltage is rapidly ramped to the creep level (equivalent to a 100mS acceleration delay).
- 10.1.8 **Cutback speeds** - Each one has an associated personality to adjust the maximum % on when the switch is active. In addition each cutback has an independently adjustable acceleration delay associated with it to further enhance low speed manoeuvrability. When both switches are active together, the lower speed is selected together with the slowest acceleration delay. The cutback speed inputs are usually normally closed so that a wire off type fault or bad connection initiates a lower speed.

If the speed limit feature is turned on when a cutback speed limit switch is closed, the cutback percentage will be applied to the maximum speed setting.

When the BDI feature is enabled and the cut-out level is reached the speed 2 cutback is automatically initiated.

A maximum speed adjustment is also available to limit the maximum applied %on. (If the setting is less than 95% then Bypass and Field Weakening are disabled).

- 10.1.9 **Bypass** - (Not available on Low I/O logic) The Bypass contactor is used to short out the main MOSFET switching device to increase speed and efficiency at high speeds and to allow higher motor currents than the controller's maximum current limit, to climb ramps laden or to escape from ruts or pot holes.

Bypass can be initiated in 2 ways:

Current-limit Bypass: the accelerator is fully depressed and the controller has been in current limit for longer than 2 seconds. In order to prevent a sudden lurch of the truck the contactor will not be energised if the motor voltage during current limit is less than 20% of battery voltage. This mode of operation can be disabled via the setup menu.

High-speed Bypass: If the accelerator is fully depressed and the controller has been pulsing at maximum % on for 1.5 seconds and the Bypass Delay personality has timed out. The Bypass delay timer is a feature that can be used to allow the truck to obtain full speed, before contactor closure.

The bypass contactor will be de-energised if the accelerator demand is reduced below 86%, or if the motor current exceeds the Bypass over-current dropout level, adjustable by the calibrator. To allow for initial overshoots the over-current test is disabled for the first 2 seconds of Bypass. Although the software attempts to minimise arcing when the contactor opens, some arcing is inevitable under certain load conditions. After an over-current drop out, the Bypass function will be inhibited until neutral is recycled to prevent repeated opening and closing of the tips under heavy current conditions.

Bypass can be disabled by setting the over-current drop out to 0 A. Also Bypass will be disabled if either of the 2 speed cutback switches are enabled and the settings are adjusted below 95% or the maximum speed setting is less than 95%. Applying the footbrake switch or economy > 0% will also prevent Bypass closure.

- 10.1.10 **Field Weakening** - (Not available on Low I/O logic) This is carried out by connecting a low value/high wattage resistor connected in series with a contactor across the traction motor field to weaken the field and hence increase speed whilst reducing torque. As a guide line the value of the resistor should be the same as the motor field resistance and it should be rated to carry field current.

At full accelerator depression and maximum %on, and after bypass contactor closure (if fitted) the field weakening contactor is energised providing the current is below the Pull-In level. If the motor current increases above the Drop-out level or the accelerator demand is less than 86% or the bypass contactor is de-energised, the Field Weakening contactor will be opened. Both the Field Weakening Drop-Out and Pull-In current levels are adjusted with the calibrator.

- 10.1.11 **Power Steer, Traction Controller** - A contactor drive is available to control a separate Power Steer motor. An adjustable delay allows the motor to operate for a set time, after the power steer trigger or power steer demand has been removed. SEVCON's standard trigger, i.e. when the contactor is closed, is when either FS1 or the Footbrake switch is closed, or the Traction unit is pulsing. It is an either-or situation, so any one of these 3 inputs is sufficient to trigger the Power Steer.

This standard trigger is designed to give power steer when ever the truck is moving, but not to have a situation where the Power steer could be on continuously, i.e. on a direction switch where the truck could be left with a direction selected and the Keyswitch left on. If FS1 or the Footbrake is applied then the vehicle is either about to move or is moving, and the Traction pulsing is used if the truck was neutral braking (pulsing) down a long ramp, when it is conceivable that neither of the 2 switches would be closed. On a tow-tractor, power steer is disabled during inching.

An independent input pin (see figures 2 & 3) also exists to trigger Power Steer operation. This is normally used in conjunction with a steer on demand system where an output is

generated when the steering wheel is turned. This gives Power steer on demand and is more efficient since typically no steering delay, or only a short delay is needed.

The independent trigger only, or other trigger combinations can be configured if necessary in the setup menu.

Some vehicles derive the power steering assistance from the main Pump Hydraulic motor, instead of having a separate Steer motor. In this situation the trigger is fed to the Pump controller and runs the pump at the speed set by the P. S. Speed personality.

Independent ramp up and ramp down delays are provided when Power steer assistance is derived from the main Pump controller, to help tune steering responsiveness without affecting the main pump operation.

10.1.12 **Regen Braking** - Regen provides vehicle braking by controlling the motor as a generator and returning the generated energy back to the battery. Regen braking reduces motor heat dissipation compared with plug braking. Regenerative braking can be initiated in 3 ways, each with an independently adjustable braking level, as follows:

i) A direction switch change will initiate Regen braking at a level set by the Direction Brake Current level. Braking effort is proportional to the accelerator position, with a minimum accelerator pedal position giving 50% of the set brake level increasing to 100% for a fully depressed pedal. The proportionality range allows the driver to modify the braking effort without allowing freewheeling. The proportionality feature is optional and can be configured in the setup menu to give fixed braking at the set personality level.

ii) Closure of the foot-brake switch in neutral, will initiate Regen braking at the Footbrake personality level. An input is provided to allow braking effort to be proportional to the Footbrake position if a potentiometer is fitted. Setting a 0 into the personality disables braking on the Footbrake switch.

iii) When neutral is selected, Regen is initiated at the Neutral Brake Current level. Setting a 0 into the personality disables neutral braking and allows freewheeling. Neutral braking will only be attempted if the % on in the previous direction exceeded 20% above the set creep level. This helps minimise unnecessary delays and contactor operations.

Regen braking is not possible at low speeds depending on the motor characteristics. To help minimise delays attempting to Regen, a Regen Time adjustment is offered which can be set so that Regen is only attempted for a short period of time, which is sufficient to initiate Regen at medium to high speeds but not to cause unnecessarily long delays at very slow speeds where Regen is not possible. If the Regen Time setting is increased then Regen can be initiated at lower speeds. Setting the Regen Time to 0 disables Regen and forces plug braking only.

If Regen is not possible due to low vehicle speed, the following action will be taken:

- 1) For direction braking, plugging will be used to slow, then reverse the vehicle.
- 2) For neutral or footbrake braking, the vehicle will freewheel.

The switching frequency in Regen is high frequency and silent.

10.1.13 **Plug Braking** - Plug braking is achieved by controlling the rotating motor armature as a generator and dissipating most of the energy in the motor and the plug diode.

For plugging-only controllers, the conditions for initiating braking are identical to those for Regen controllers: on a direction change, footbrake switch and in neutral. Plugging also operates on Regen controllers if the truck has been travelling too slowly to initiate Regen direction braking.

The switching frequency in the Plug braking mode is 6KHz.

10.1.14 **Inching** - This facility is normally used on Tow Tractors to manoeuvre the Tractor towards the load from the rear of the vehicle, using 2 inching buttons, one for forward and one for reverse. The inch speed is adjustable via the calibrator.

Inching will only operate if the main direction control and FS1 switches are in the neutral position and the seat switch is open, and handbrake off. These safety interlocks prevent anyone from sitting in the driver's cab whilst an operator is using the inching switches at the rear.

A burst inching feature is also available which uses inching in conjunction with an adjustable timer to provide inching for a limited period. This is typically used in conjunction with an electromechanical brake to provide inching on gradients and to help prevent against unlimited travel if an inching button became jammed in the closed position or failed short circuit.

The controller can be configured to release the electrobrakes when inching occurs, by setting menu 1.6.33, Inch E-Brake, to on. If this is set-up item is set to off, the electrobrakes will not be released during inching.

10.1.15 **Anti-Rollback** - This is a standard SEVCON feature and is used to help prevent roll back conditions on ramps. If the driver reselects the previous direction after a neutral condition, braking is not attempted, and full drive power is available to restart on a hill.

10.1.16 **Analogue Inputs** - The accelerator/analogue inputs are flexible in the range of signal sources they can accommodate and can be adjusted to minimise dead-bands and mechanical tolerances. Each analogue inputs has 2 adjustments associated with it, that allow the input voltage range to be determined.

For the Traction Accelerator, for example, the 2 adjustments are called the “Accelerator Zero Level” and the “Accelerator Full Level”. If these were set to 0.20V and 4.80V then 0% pulsing would start at 0.20V at the input, increasing to 100% pulsing at 4.80V. For accelerators with decreasing voltage outputs, the Zero adjustment might be set to 3.5V and the Full adjustment to 0.0V. The Calibrator test menu shows the instantaneous voltage reading, and the equivalent % “push” for each input, and to allow easy set-up, pressing the “down” key on the calibrator from either of these test displays, allows a direct jump to the Zero voltage and Full voltage personality settings. Note that a 6 flash fault will occur if the full and zero levels are set within 0.50V of each other.

For wiring details see Figures 1 to 3.

10.1.17 **Traction Accelerator** - When Drive is selected and the accelerator is first pressed, pulsing will commence at the Creep Speed setting increasing towards the maximum %on.

If the accelerator is depressed at power up, pulsing will be inhibited and a 6 flash fault will be indicated, until the pedal is released. In case of a wire off type fault, pulsing will be limited to the creep setting and a 6 flash fault will also be given.

Various accelerator characteristics i.e. relationship between accelerator push and the applied motor voltage, can be selected via the setup menu. There are 4 options: Linear, Curved, 2*slope and Crawl. Set to Linear for a straight line accelerator characteristic, Curved for more low speed manoeuvrability, 2*Slope for a balance between Linear and Curved, and Crawl for a very shallow low speed manoeuvrability curve. See graph 2 for actual characteristics.

10.1.18 **Footbrake Potentiometer** - This input is available to allow a potentiometer to be fitted to the Footbrake pedal for proportional braking. It can be connected and set-up as per the accelerator input. Note that footbrake operation drops out both Bypass and Field weakening.

10.1.19 **Footbrake Switch** - This input is available to allow a switch to be fitted to the Footbrake pedal for constant braking. Note that footbrake operation drops out both Bypass and Field weakening.

10.1.20 **Economy Potentiometer** - This potentiometer, normally available to the driver of the truck, varies the acceleration ramp delay from its set value to its maximum value. It can be adjusted as per the accelerator input. As a setup menu option the economy function can reduce the traction current limit, instead of increasing the acceleration delay. Note that the economy function drops out both Bypass and Field Weakening.

10.1.21 **Over-Temperature Sensor**- This input is available for overtemperature sensors which are attached to the traction or pump motors. The input will reduce the traction or pump current limit from maximum to 1/3 current limit, similar to the economy cuts current limit function. If a Full Feature Display is fitted, the over temperature symbol (thermometer) and the traction or pump identifier will be displayed.

10.1.22 **Digital Switch Inputs** - The digital inputs on the controller can be configured as Active Low inputs, where the switches are wired to B-ve. Active High inputs, connecting to B+ve,

are not available. The SEVCON standard is Active Low, and is recommended for its low impedance input stage and immunity to moisture related problems.

A further configuration allows each input to be specified as normally open or normally closed. Most switches are normally open, with the exception of the 3 speed cutback switch inputs which are normally closed, so that a wire off type fault, or bad connection initiates the cutback speed, rather than a higher speed. On compensated Pump systems the Power Steer input can be conveniently configured as normally closed.

- 10.1.23 **Contactors** - The Pump logic has no contactor drives. The Low I/O logic has 3 outputs for driving contactors, the medium I/O has 5 outputs and the High I/O has 10. On Medium and High I/O logics it is also possible to reconfigure an output, as an external LED or Lamp driver to allow dashboard indication of the controller's integral LED.

The controller can diagnose open circuit (o/c) and short circuit (s/c) problems with certain contactors, as described in the diagnostic section. Generally, following a request to open a contactor, the controller will report a 4 flash fault and a calibrator message if a successful operation was not detected after approximately 500ms. To help prevent against minor tip contaminants causing spurious diagnostic trips when closing a contactor, if a closure is not detected after 500ms, pulsing up to a maximum of 25% is allowed. This is designed to pass a controlled amount of current to try and break through any contaminant present to allow uninterrupted drive. If a closure isn't detected on reaching 25%, then the contactor drive is removed and a 4 flash fault is indicated.

An optional Line Contactor, not controlled from the controller, can be connected between the B+ terminal of the controller and battery positive. A diode should be fitted in series with the line contactor coil to prevent large currents flowing through the battery connectors and into the internal capacitors when the controller is first connected to the battery. After the keyswitch has been switched, and once the capacitors have charged up (via internal resistance) the line contactor will be energised. An internal diode fitted in the keyswitch line will prevent any contactor energising if the polarity of the battery voltage is reversed. On Pump controllers the Line Contactor also gives a mechanical break.

Under normal operating conditions contactors will operate without arcing. However, under certain fault conditions, contactors may arc when opening. The Bypass contactor may also arc during Bypass over-current drop out conditions.

- 10.1.24 **Contactor chopping** - This feature allows 24 V contactors to be used at all battery voltages 24V - 80V, by continuously monitoring the battery voltage and chopping the contactor output pins accordingly, to present an average voltage suitable for 24V coils. Chopping is selectable by the calibrator. All the contactor drives will be either chopped or not chopped. It is not possible to select individual drives to chop. Care must be taken to ensure that chopping is always selected if 24V contactors are being used on battery voltages higher than 24V. In applications > 24 volts contactors must be fitted with blow out magnets.

Chopping can reduce the overall dissipation in the coils and allows only one set of contactors to be stocked for all battery voltages.

Chopping Frequency approx. = 650Hz (Slightly audible at higher battery voltages)

Typical contactor coil voltage during chopping = 16 volts.

Typical contactor coil voltage during energisation = 24 volts for 1 second.

There are 3 contactor chopping options available via the setup menu: Off, On and 24V. The off setting is used for nominal battery voltage coils, and the On setting is for 24V coils on higher voltage vehicles. Setting to 24V provides chopping for 24V coils and lamps without the drop to 16V after 1s.

- 10.1.25 **Fail-safe** - The controller's safety system includes a microprocessor watchdog which can detect software failure, and a hardware fail-safe system which can prevent dangerous runaway conditions in the event of certain hardware failures.

Every time the controller is powered-up, the software checks that the fail-safe circuit is able to switch off the MOSFETs and open the contactors.

10.1.26 **Speed Limit** - (Not available on Low I/O logic) A traction speed limit in KPH can be set via personality 1.1.36 (0 KPH disables the feature). As the speed of the vehicle approaches the limit, the maximum motor voltage is reduced. If the speed limit is exceeded by more than 2 KPH (when the vehicle is travelling down-hill for example) electrical braking will be used until the speed of the vehicle falls to below the limit. Speed limit braking may operate in normal drive (as described above), to increase existing braking torque if the vehicle over-speeds, or if the vehicle is rolling in neutral.

The actual limit speed of the vehicle is typically ± 2 KPH of the personality setting, depending on motor loading. When the feature is enabled, a probe “wire-off” feature will limit the motor voltage if the probe is disconnected.

Calibration of the feature is made via the set menu items “Full Speed” (1.6.29) and “Probe Frequency” (1.6.30). Full Speed should be set to the maximum speed of the vehicle, unloaded on level ground. The Probe Frequency setting should be the output frequency of the sensor at that speed.

The recommended sensor is an active low (i.e. NPN) inductive proximity switch. The output is connected to the customer connector, pin 9. A +12V supply on the customer connector pin 12 can be used for most types of sensor. The negative supply of the sensor should be connected to the controller’s B- terminal. Contact SEVCON for further recommendations if required.

If the speed limit feature is turned on when a cutback speed limit switch is closed, the cutback percentage will be applied to the maximum speed setting.

10.1.27 **Sideloader** - (Only available on High I/O logic when contactors 9 & 10 are configured to Forward and Reverse). If the sideloader switch is active, this will reverse contactors 9 & 10 when compared to contactors 1 & 2 e.g. if the forward direction is selected and the sideloader switch is active, contactor 1 (FORWARD) = CLOSED, 2(REVERSE) = OPEN, 9(FORWARD) = OPEN and 10(REVERSE) = CLOSED. The sideloader switch is only acted upon when the controller is in a neutral state (no driving or braking). The application must ensure that the vehicle is at a standstill before the switch input is changed.

10.2 **PUMP OPERATION**

10.2.1 **Pump Operation** - There is no start-up sequence, so pulsing will be initiated after a small delay at power-up if one or more of the pump switches is selected. There are adjustable ramp up and ramp down delays. A Pump contactor can be specified as an option. There are facilities for prioritising pump speeds, for having different pump speeds added together and for having speed compensation for different load conditions.

10.2.2 **Pump Speeds and Priorities** - Each of the 5 pump switch inputs has its own speed setting. The pump speeds are prioritised in numerical order so that Speed 1 has priority over all other speeds and Speed 2 has priority over Speeds 3 to 5, etc. Example:- If Speed 1 is set to 10%, Speed 2 to 20% and Speed 3 to 30% then selecting Speeds 1 and 3 will give 10% and selecting Speeds 2 and 3 will give 20%.

10.2.3 **Additive speeds** - Pump switches 5 and 6 can be adjusted to have an “Additive” speed. In this mode, the switch is excluded from the priority system described in 10.2.2; instead its speed is added to the prioritised pump speed to give increased power required to handle simultaneous pump operations.

Example:- If speed 2 is set to 40%, speed 5 is set to 25% and speed 6 is set to 10%, then selecting all three switches will give a demand of 75%, and selection 2 and 6 alone will give a demand of 50%.

10.2.4 **Pump accelerator inputs** - The pump accelerator demands are associated with Speeds 1 & 2. The pump will operate at the Creep Speed setting when the accelerator is at minimum demand and change linearly to Speed 1 or 2 as the accelerator is increased to the maximum demand. The pump pot accelerator input can be connected and adjusted as per the previously described traction accelerator input.

- 10.2.5 **Economy Potentiometer** - This potentiometer if configured varies the pump current limit. 0% economy gives maximum current and 100% economy gives 1/3 of maximum current.
- 10.2.6 **Power Steer speed** - On compensated pump systems this setting can be used to control the power steer speed from the main pump motor. This speed is selected from the power steer trigger input as previously described and can be compensated for as described in the section below. The power steer also has independent ramp up and ramp down delays. See the section 10.1.11 on Power Steer for more information.
- 10.2.7 **Pump Speed Compensation** - Some trucks utilise the main hydraulic pump motor to provide power steering assistance, instead of a separate power steer motor. This feature provides speed compensation so that the pump motor always provides steering assistance, whilst allowing the motor to slow down when assistance isn't required to minimise noise and improve efficiency. Pump speeds 1 - 4 and the Power Steer speed can be compensated if required.

The compensation is a straight line characteristic set up using 2 personalities. The set up procedure may require some repetition to give optimum performance of low load (low noise) and full compensated load. The low load speed is normally set up to run the pump motor at its lowest permissible lubrication speed to keep audible noise to an absolute minimum.

The calibrator's base speed sets up the low load speed and the compensation factor sets the amount of boost when the controller detects a current increase due to the pump motor load increasing. The controller monitors the motor current and changes the motor voltage to ensure that the motor remains on this compensated speed line.

Set up Procedure - Set both the base speed and the compensation factor to 0. Activate the pump switch associated with the speed to be compensated. Ensure that the motor has its minimum load. Increase the Base speed until the correct operating speed at minimum load is achieved. Increase the load associated with this pump speed to its maximum. Increase the compensated speed until varying the load has little or no effect on the speed.

Example - Power steer compensation where the main pump motor provides the hydraulic steering assistance. Set the Power Steer personality base speed and compensation factor to 0. Activate the Power Steer Trigger input and increase the Power Steer base speed until the pump motor is running at its desired low speed. Operate the steering. Very little assistance will be given if the pump is going slow. Increase the Power Steer compensation setting until the required amount of assistance is given when the steering is operated. The set-up is an iterative process so it may be necessary to change the base speed again and repeat the procedure to obtain optimum results.

10.3 GENERAL OPERATION

10.3.1 **Operating Frequency** - The drive frequency of both the Traction and Pump power frames is 16KHz, for silent operation. For Traction Regen-braking the frequency is also 16KHz, whilst Plug braking is 6KHz.

10.3.2 **Temperature Monitoring** - If the temperature of either power frame exceeds 75°C its maximum available current will be reduced. Note, however, that if the set current limit is less than the maximum available current limit actual cutback will occur at progressively higher temperatures than 75°C. The thermal cutback ensures that the maximum heatsink temperature is limited to 95°C (See Graph 1). When cutback occurs the diagnostic LED will flash 8 times.

10.3.3 **Safe Operating Area (SOA)** - The controller's current may be limited at high and/or low duty cycles depending on its current and voltage specification. This is to reduce the thermal stress on the power components in order to increase long term reliability. See Graph 2.

The "Safe Operating Area" is a characteristic of the MOSFETs and Freewheel Diodes which make up the power-frame. The MOSFET SOA restricts current at high duty cycles on all configurations, and the Diode SOA tends to restrict the current at lower duty cycles on lower voltage applications.

For most applications SOA will have little or no effect on the operation of the controller. Its effect is more significant in protecting the controller against adverse loads such as damaged motors and static test rigs.

10.3.4 **Under-voltage and over-voltage protection** - In order to prevent a sudden loss in power, the controller will begin to linearly ramp down the current limit, once the average battery voltage falls below a pre-set under-voltage start level. The current will be ramped down to 0 and a 7 flash fault indicated if the averaged battery voltage falls below the under-voltage cutout level.

To protect the controller from over-voltage caused by prolonged regen braking, regen braking will be terminated and plug braking initiated when the average battery voltage reaches the over-voltage start level. If the voltage exceeds the over-voltage cutout level in braking then all contactors will open and freewheeling will occur, requiring the vehicle's mechanical brakes to be used.

Under any other circumstances if the battery voltage exceeds the over-voltage cutout level, all pulsing is stopped and a 7-flash fault is indicated. This protects against incorrect battery connection.

Nominal Battery Voltage	Under-voltage Cutout	Under-Voltage Start	Over-voltage Start	Over-voltage Cutout
24 V	14.5 V	18.0 V	40.0 V	45.0 V
48 V	29 V	36.0 V	65.0 V	70.0 V
80 V	43.0 V	60.0 V	95.0 V	97.5 V

10.3.5 **Diagnostic LED** - This is mounted between the connectors on the front of the controller. It serves as a simple diagnostic tool as explained below:

Constant illumination	- No fault, normal condition
LED extinguished	- Internal controller fault
1 flash	- Personality out of range
2 flashes	- Illegal start condition
3 flashes	- MOSFET Short Circuit
4 flashes	- Contactor fault or Motor Open-Circuit
5 flashes	- Not used
6 flashes	- Accelerator or Speed Probe wire off fault
7 flashes	- Low or High battery voltage or BDI cut-out operating
8 flashes	- Over temperature
9 flashes	- Contactor coil s/c
12 flashes	- CANbus fault

Further explanation of the LED flashes are displayed on the calibrator fault message section.

10.3.6 **Fault Clearance** - Any fault indication will be cleared by re-initiating the start sequence after the cause of the fault has been removed.

10.3.7 **Software Version and Revision indication** - For identification purposes and to assist in queries, the Software version and revision, and the controller serial number are indicated in the calibrator Test Menu.

10.3.8 **Dashboard Displays** - SEVCON's existing CAN based standard and full feature displays are compatible with PowerpaK controllers.

10.3.9 **Setup Menu** - A setup menu has been added to the Calibrator that allows various features to be enabled and disabled. See section 7 for more information.

Note. Once a change has been made to the setup menu, the Key switch must be recycled for the change to be operational.

10.3.12 **Multi Languages** - Non-English languages can be specified for displaying on the Calibrator. Languages can be presently specified as either English, German, Spanish, Italian or French. NOT AVAILABLE AT PRESENT.

11 DASHBOARD DISPLAYS - OPERATION AND FEATURE DESCRIPTIONS

SEVCON offers 2 dashboard mounted CAN (Controller Area Network) Displays for any SEVCON controller equipped with serial CAN communications, including the PowerpaK range. A standard display offers a compact design compatible with 2" dashboard hole mounting, and a full-feature display offers a higher specification LCD. Both are back-lit for use in low ambient light conditions.

Both displays have BDI Indication, and 4 hours-counters. The hours counters are retained in the display in the event of the controller or the controller's logic being replaced in the field.

11.1 STANDARD DISPLAY

The unit consists of a 2x16 alphanumeric LCD display housed in a standard 50mm circular plastic case, with a rectangular front facia. The display incorporates a 10 segment BDI (Battery Discharge Indicator), a 6 digit hours counter and a 10 character area for diagnostic and status messages. When there are no diagnostic messages the area can be used to indicate a variety of system status readings.

11.1.1 STANDARD DISPLAY FEATURES.

- * One unit for 24V-96V.
- * Standard 50mm circular case with rectangular front facia, enclosed to IP65
- * Alphanumeric display 2x16 characters.
- * Readily understandable display format consisting of numbers, text and segments.
- * 10 segment BDI indication, with low charge warning and cut-out warnings.
- * 10 character text based diagnostic/status display.
- * 6 digit hours counter with 0.1 hour indication, and flashing "egg timer" counting symbol.
- * Capable of counting up to 99999.9 hours. Equates to 34 years @ 8 hour shift per day
- * Keyswitch, Traction and Pump hours count can be shown, identified as K, T, P.
- * Hours count retained in display in the event of a controller or logic replacement.
- * Display connected via single cable, no external power connections necessary.

Display example showing diagnostic message



11.1.2 STANDARD DISPLAY TECHNICAL SPECIFICATIONS

11.1.2.1 Environmental

Protection (front face):	IP65
Protection (rear):	IP34
Vibration:	6G, 0-150Hz for 1 hour
Operating Temperature:	-5°C to +50°C
Storage Temperature:	-40°C to +85°C
Humidity:	95% maximum, non-condensing
Humidity Resistance:	No functional defects after display is left at 60°C and 100% humidity for one hour after freezer use (-30°C minimum).

11.1.2.2 Mechanical

Mounting Hole:	2" Nominal. (See mechanical drawing)
Unit weight:	0.12 Kg (including mounting bracket)
Enclosure:	Injection moulded plastic case, with transparent front facia.
Connections:	One 6 way AT socket.
Fixings method:	Mounting bracket supplied

11.1.3 Electrical

Power Supply:	Derived from CANbus
Supply Current	60mA (typical)

11.2 FULL-FEATURE DISPLAY

The unit consists of a custom graphic LCD display housed in a SEVCON designed rectangular plastic case. The display incorporates a 10 segment BDI (Battery Discharge Indicator), a 6 digit hours counter and a 14 character area for diagnostic and status messages. The display has 11 warning symbols which can be lit by the controller (via the CANbus) or by 8 active low switch inputs. When there are no diagnostic messages the top line of the message area can be used to indicate one of a number of status readings (see “display related adjustments” below). In addition there are two multipurpose indicators, that can be reprogrammed using the calibrator to show one of a selection of system status readings.

11.2.1 FULL-FEATURE DISPLAY FEATURES

- * One unit for 24V-96V.
- * SEVCON-designed full-custom LCD with LED backlight.
- * Readily understandable display format consisting of numbers, text and segments.
- * 10 segment BDI indication, with low charge warning and cut-out warnings.
- * 14 character text based diagnostic/status display.
- * 6 digit hours counter with 0.1 hour indication, and flashing “egg timer” counting symbol.
- * Capable of counting upto 99999.9 hours. Equates to 34 years @ 8 hour shift per day
- * Keyswitch, Traction and Pump hours count can be shown, identified as K, T, P.
- * Hours count retained in display in the event of a controller or logic replacement.
- * Speed indication (indicator #2), can be reprogrammed via calibrator.
- * Text status area can show one of a selection of system status readings.

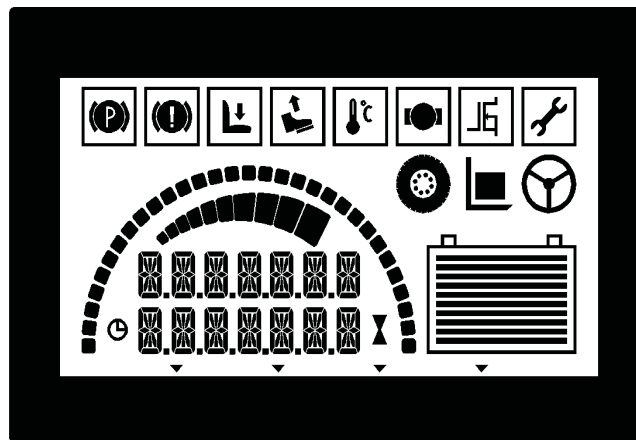

Full Feature Display with all segments lit.

11.2.2 FULL-FEATURE DISPLAY TECHNICAL SPECIFICATIONS

11.2.2.1 Environmental

Protection:	The enclosure is protected to IP65
Vibration:	6G, 40-200Hz for 1 hour
Operating Temperature:	-20°C to +70°C
Storage Temperature:	-40°C to +85°C
Humidity:	100% maximum, with condensing

11.2.2.2 Mechanical

Mouting hole:	128mm x 87mm (see mechanical drawing)
Unit weight:	0.35 Kg.
Enclosure:	Injection moulded plastic case, with transparent front facia.
Connections:	One 6 way AT socket, One 12-way.
Fixings method:	Mounting bracket supplied

11.2.2.3 Electrical

Power supply:	Derived from CANbus
Supply current:	60mA (typical)
Backlight supply	14.5V to 150.0V
Backlight supply current	50mA (typical)

11.2.2.4 12-Way Connections

<u>Pin</u>	<u>Type</u>	<u>Description</u>
1	Digital i/p	Traction Motor Temperature Warning
2	Digital i/p	Pump Motor Temperature Warning
3	Digital i/p	Power Steer Motor Temperature Warning
4	Digital i/p	Traction Motor Brush Wear
5	Digital i/p	Pump Motor Brush Wear
6	Digital i/p	Power Steer Motor Brush Wear
7	Digital i/p	Oil Warning
8	Digital i/p	Diagnostic/Service Warning
9	0V	Return for swtich inputs, pins 1-8
10	PSU i/p	Battery negative (backlight supply)
11	spare	
12	PSU i/p	Battery positive (backlight supply)

11.3 DISPLAY RELATED ADJUSTMENTS

11.3.1 Hours counter, Display status and Contrast adjustments (On pump only systems located in Pump sub menu 2.8)

Cal. Ref.	DISPLAY Parameter Adjusted	Minimum or default setting.	Maximum or other settings.	Step size.
1.8.1	Main Hours	Trac	Pump, Key, Work	n/a
1.8.2	Status	Off	Ver #	n/a
1.8.3	Contrast (standard only)	0	127	1
1.8.4	Indicator 1 (FFD Only)	Off	Ver #	n/a
1.8.5	Indicator 2 (FFD Only)	Off	Ver #	n/a
1.8.6	Fault Messages	On	Off	n/a

1.8.1 The main hours adjustment is used to select which of the hours counters: Keyswitch (“K”), Traction (“T”) or Pump (“P”) hours, remains on the display after power-up sequencing, Normally this is Key (“K”).

1.8.2,4,5 Selects a system status reading for display (or indication on the full-feature display) from: Off, Traction motor current, Traction motor voltage, Pump motor current, Pump motor voltage, vehicle speed in KPH, vehicle speed in MPH, Accelerator pushes and display software version number (not available on indicator 1 or 2).

1.8.3 Sets the contrast of the standard display.

11.3.2 BDI adjustments (Located at the end of the first Traction sub menu 1.4, or in Pump sub menu 2.4)

Cal. Ref.	BDI Parameter Adjusted or displayed	Minimum setting or displayed value	Maximum or other settings	Step size
1.4.1	xxx % Charge remaining	n/a	n/a	n/a
1.4.2	Battery Volt xx V	24V	96V	2V
1.4.3	Reset x.xx V/Cell	2.00	2.50	V/Cell
1.4.4	Empty x.xx V/Cell	1.50	1.99	V/Cell
1.4.5	Warning xx %	0%	90%	1.0 %
1.4.6	Cutout xx %	0%	90%	1.0 %

WARNING: The BDI Empty level must be set in accordance with the specification of the battery fitted to the vehicle. Setting the Empty level lower than the battery manufacture’s specified discharged level can result in permanent damage to the battery.

1.4.1 Displays the remaining battery charge. No adjustments can be made.

1.4.2 Adjustment used to enter the nominal battery voltage.

1.4.3 Sets the voltage at which the BDI resets to 100% at power up. E.g. the BDI will reset to 100% on a 48V system, with the reset adjustment set to 2.20 Volts per cell, if the battery voltage is above $52.8V = (48V/2)*2.20V$.

1.4.4 Sets the voltage at which the BDI indicates the battery is fully discharged E.g. the BDI will eventually show 0% on a 48V system, with the empty adjustment set to 1.60 Volts per cell, if the battery voltage is below $38.4V = (48V/2)*1.60V$.

1.4.5 Sets the discharged level at which the warning threshold is reached, and the unlit segments flash.

1.4.6 - Sets the discharged level at which the cut-out threshold is reached. All BDI segments flash, pump operation is cut, and cutback 2 is applied to traction.

11.4 BDI OPERATION

The state of battery charge is indicated by 10 segments on the display. When the battery is deemed fully charged, all 10 segments will be lit. When the battery is deemed fully discharged all segments will be extinguished, with each 10% drop in capacity extinguishing 1 segment. There are 5 adjustments associated with the BDI as described on the previous page, adjustable by the hand held calibrator.

When the battery charge drops below an adjustable warning level, typically set to 30%, the remaining lit segments will flash to warn the driver of this. When the charge drops further to below an adjustable cut-out level, typically 20%, all 10 segments will flash. At the cut-out level, Pump operation will be inhibited at the end of its present operating cycle, and cutback 2 personalities will be applied to the Traction.

The state of battery charge is retained even when power is removed, and is stored in the controller's non-volatile EEPROM memory. At power up the display will always indicate the previous state of charge for approximately 1 second, whereupon it will either continue to display this, or revert to a fully charged indication if the battery is deemed to have been charged in the meantime. The BDI system uses an averaged, accurate battery voltage to deduce the state of charge. Pin 10 on connector 2 is the Battery voltage measurement input for the BDI and to maintain accuracy should be connected as close as possible to the actual battery terminals, without overriding safety disconnects.















11.5 HOURS COUNTER (INDEPENDENT FROM CONTROLLER HOURS COUNT)















A 6 digit hours counter is provided to indicate Traction pulsing, Pump pulsing and Key switch hours. The last digit displays tenth's of hours, i.e 6 minute intervals, with the counter capable of displaying up to 99999.9 hours in total. As a guideline, this is equivalent to approximately 34 years operation if the truck was used for an 8 hour shift every day.

At power up the hours count display initially indicates Key switch hours for approximately 3 seconds, followed by Pump pulsing hours for 3 seconds(if applicable), followed by Traction pulsing hours which remains permanently displayed. This order can be changed using the calibrator as described on the previous page. When the hours are being counted, a flashing egg timer symbol is displayed to indicate this. Hours counting accuracy is approx. +/- 2%. The display has its own integral non-volatile memory to retain all the hours counts in the event of the controller or controller logic being replaced.

11.6 DIAGNOSTIC/STATUS TEXT MESSAGES

The controller can transmit text messages for diagnostic and status indication. On the standard display these appear over the status area, and on the full-feature display, they also overwrite the hours counter until the fault condition has cleared. This feature can be disabled via personality 1.8.6 as described on the previous page. Some messages may be displayed with one or more symbols. The following table shows the fault message and symbols displayed for each fault condition.

Message		Symbols Displayed	Fault Description
1	TRAC BRUSHES		Traction brushes worn.
2	PUMP BRUSHES		Pump brushes worn.
3	PUMP HOT		Pump over temperature.
4	OIL FAULT		Oil pressure low.
6	PUMP HOT		Pump motor too hot.
7	BDI CUT OUT		BDI enabled and cut-out action initiated.
8	TRAC HOT	 	Traction heatsink above 75°C. Allow controller to cool
9	PUMP HOT	 	.Pump heatsink above 75°C. Allow controller to cool.
10	SPEED PROBE		Speed limit feature enabled & wire off.
11	ACCEL FAULT		Accelerator wire off. Recycle FS1 and Direction.
12	ACCEL FAULT		Accelerator pedal pressed at power up, or wire off. Recycle FS1 and Direction.
13	CONTACT FAULT		Contactor has bad contact or didn't close, motor o/c. Recycle FS1 & Dir.
14	CONTACT FAULT		Contactor didn't open or is welded. Recycle FS1 and Direction switch.
15	SEQ FAULT		Direction or FS1 switch at power up. Recycle Direction FS1 or both.

16	2 DIR FAULT		Two directions selected together. Recycle both Directions and FS1.
17	SRO FAULT		Dir. switch selected > 2 seconds after FS1. Recycle FS1 and Dir.
18	SEAT FAULT		Drive selected and no seat sw. Recycle Dir and FS1 switch
19	BELLY FAULT		Belly switch has pressed
20	INCH FAULT		Inch switch at power up , both inch switches selected or inching attempted with seat switch or Dir/FS1 selected. Recycle inch switches.
21	BATTERY LOW		Battery < Low battery personality. Recycle FS1 or Direction switch
22	BATTERY HIGH		Battery > High battery personality. Recycle FS1 or Direction switch
23	PERS ERROR	 	Personalities out of range at power up.
24	CRC ERROR	 	One or more personalities have been corrupted.
25	COIL FAIL	 	A contactor coil s/c or miswired. Recycle Keyswitch
26	MOSFET FAIL	 	Bypass contactor s/c or MOSFET s/c Recycle FS1 or Direction
27	FAIL	 	If any of these message are displayed then the controller has failed one of its internal power up checks.

The main switching element of the PowerpaK consists of a bank of power MOSFET transistors connected in parallel. These are switched at high frequency (16KHz) to give silent operation. Switching speeds have been optimised to minimise switching losses.

Fast-recovery Freewheel diodes, also connected in parallel but arranged to share current, are used to maintain circulating current around the motor when the main MOSFETs are turned off.

Both the MOSFETs and Freewheel diodes have their temperatures monitored. The software will cutback motor current to prevent either thermal stress, or operation outside their safe operating areas.

Electrolytic capacitors are fitted internally between B+ve and B-ve to maintain constant current in the battery leads and to keep a constant battery voltage across the controller.

In traction power frames a Plug Diode is internally connected across the motor armature to limit the generated voltage during plugging so that controlled braking can be achieved. This diode is not necessary for Pump motor controllers.

On traction controllers, Regen is achieved by adding an extra single pole change over contactor and an optional regen diode which connects the top of the motor armature to B-ve during braking, to allow circulating generated current to flow round the motor loop after the direction contactors have been reversed and the motor excited. The generated armature voltage charges the motor field with current when the MOSFETs are on. When they are off, this current flows through the freewheel diodes back into the battery. This has the effect of returning a small amount of energy back to the battery and minimising heat dissipation in the motor during braking.

A current shunt is connected in series with the motor armature to monitor motor currents, during all operations including drive, regen and plug braking modes.

On traction controllers the direction contactors should be used to switch the armature. A line contactor can be used to offer reverse battery connection protection, minimise any battery connector arcing when powering up, and to give a mechanical break in pump controller systems. The line contactor is optional, and is not operated by the Controller.

Bypass operation is possible on traction systems to short out the main MOSFET devices for maximum efficiency and high speed or high current operation. Field Weakening operation is also possible on traction controllers by controlling a contactor to switch in resistor in parallel with the motor field. An output for controlling a power steer contactor is also provided.

13 INSTALLATION

- 13.1 The controller should be bolted down to a flat (0.2mm max. deviation) paint free surface that has been lightly coated with a thermal transfer compound, such as GE G641 or Dow Corning heatsink compound, by the 6 fixing holes provided. Care should be taken not to trap any wires, etc., under the controller. The mounting surface **MUST** be a substantial metal section of the truck for the full controller ratings to be achieved.
- 13.2 Power connections should be made with flexible heat resisting cables of suitable cross-sectional area for the current to be carried (See section 6.1.2). These should be terminated in soldered or crimped lugs attached to controller and the contactors. Note that nuts and washers are supplied for the M8 connections on the controller. A battery-disconnect switch should be used (EC Directive).
- 13.3 The contactor mounting plane can affect performance, contactors should never be mounted with their terminal studs vertically down. For further applications information on contactors, please consult SEVCON.
- 13.4 The controller may be supplied as a stand-alone unit or pre-wired onto a base-plate with contactors etc. If the controller is 'stand-alone', both Connectors 1 and 2 will be used. If a 'panel' is supplied, only Connector 1 will be used as Connector 2 will contain the contactor wiring. The mating halves of the connectors can be supplied with the controller as a 'loose equipment kit'.
- 13.5 Control wiring connections should be made using 1.00mm² (AWG#18) or equivalent stranded wire. The correct pressure release crimping tools **MUST** be used for long term connection reliability.
- 13.6 The main battery cable should be fused with a suitable air-break fuse. The keyswitch line must also be fused at a level not exceeding 10 A when using the specified Albright contactors.
- 13.7 The return wiring for the accelerators should be connected to the B- terminal on the controller to prevent large currents altering accelerator signals.
- 13.8 Fixing torque for power connectors
M8 terminals 11NM

14 EMC GUIDELINES

The following guidelines are intended to help vehicle manufacturers to meet the requirements of the EC directive 89/336/EEC for Electromagnetic Compatibility.

Any high speed switch is capable of generating harmonics at frequencies that are many multiples of its basic operating frequency. It is the objective of a good installation to contain or absorb the resultant emissions.

All wiring is capable of acting as a receiving or transmitting antenna. Wiring should be arranged to take maximum advantage of the structural metal work inherent in most vehicles. Vehicle metalwork should be electrically linked with conductive braids.

14.1 Power Cables

All cables should be routed within the vehicle framework and kept as low in the structure as is practical - a cable run within a main chassis member is better screened from the environment than one routed through or adjacent to an overhead guard.

Power cables should be kept short to minimise emitting and receiving surfaces

Shielding by the structure may not always be sufficient - cables run through metal shrouds may be required to contain emissions.

Parallel runs of cables in common circuits can serve to cancel emissions - the battery positive and negative cables following similar paths is an example.

Tie all cables into a fixed layout and do not deviate from the approved layout in production vehicles. A re-routed battery cable could negate any approvals obtained.

14.2 Signal Cables

All wiring harnesses should be kept short.

Wiring should be routed close to vehicle metalwork.

All signal wires should be kept clear of power cables or made from screened cable

Control wiring should be kept clear of power cables when it carries analogue information - for example, accelerator wiring.

Tie all wiring securely and ensure wiring always follows the same layout.

14.3 Controller

Thermal and EMC (emissive) requirements tend to be in opposition.

Additional insulation between the controller assembly and the vehicle frame work reduce capacitive coupling and hence emissions but tend to reduce thermal ratings. A working balance needs to be established by experiment.

The complete installation should be documented, in detail, and faithfully reproduced on all production vehicles. When making changes, consider their effect on compliance ahead of any consideration of cost reduction or other "improvement".

STANDARD SEVCON POWER UP, SEAT SWITCH AND SRO SEQUENCING DESCRIPTION

KEY SWITCH POWER UP TRUTH TABLE (NO SRO ENABLED)						
	Key Sw.	Seat Sw.	Direction Sw.	FS1 Sw.	Drive	Fault Indicated
1-8	0	x	x	x	No	None
9	1	0	0	0	No	None
10	1	0	0	1	No	None
11	1	0	1	0	No	None
12	1	0	1	1	No	Seat Fault
13	1	1	0	0	No	None
14	1	1	0	1	No	None
15	1	1	1	0	No	None
16	1	1	1	1	Yes	None
KEY SWITCH POWER UP SEQUENCE TABLE (NO SRO ENABLED)						
1	Key	Seat	Direction	FS1	Yes	None
2	Key	Seat	FS1	Direction	Yes	None
3	Key	Direction	Seat	FS1	No	Seat Fault
4	Key	Direction	FS1	Seat	No	Seat Fault
5	Key	FS1	Seat	Direction	No	Seat Fault
6	Key	FS1	Direction	Seat	No	Seat Fault
7	Seat	Key	Direction	FS1	Yes	None
8	Seat	Key	FS1	Direction	Yes	None
9	Seat	Direction	Key	FS1	No	Power Up Fault
10	Seat	Direction	FS1	Key	No	Power Up Fault
11	Seat	FS1	Key	Direction	No	Power Up Fault
12	Seat	FS1	Direction	Key	No	Power Up Fault
13	Direction	Key	Seat	FS1	No	Power Up Fault
14	Direction	Key	FS1	Seat	No	Power Up Fault
15	Direction	Seat	Key	FS1	No	Power Up Fault
16	Direction	Seat	FS1	Key	No	Power Up Fault
17	Direction	FS1	Key	Seat	No	Power Up Fault
18	Direction	FS1	Seat	Key	No	Power Up Fault
19	FS1	Key	Seat	Direction	No	Power Up Fault
20	FS1	Key	Direction	Seat	No	Power Up Fault
21	FS1	Seat	Key	Direction	No	Power Up Fault
22	FS1	Seat	Direction	Key	No	Power Up Fault
23	FS1	Direction	Key	Seat	No	Power Up Fault
24	FS1	Direction	Seat	Key	No	Power Up Fault

SEAT SWITCH TRUTH TABLE (NO SRO ENABLED)						
	Seat Sw.	Seat Timer	Direction Sw.	FS1 Sw.	Drive	Fault Indicated
1	0	0	0	0	No	No
2	0	0	0	1	No	No
3	0	0	1	0	No	Seat Fault
4	0	0	1	1	No	Seat Fault
5	0	1	0	0	No	No
6	0	1	0	1	No	No
7	0	1	1	0	No	No
8	0	1	1	1	Yes	No
9	1	x	0	0	No	No
10	1	x	0	1	No	No
11	1	x	1	0	No	No
12	1	x	1	1	Yes	No
13	1	x	0	0	No	No
14	1	x	0	1	No	No
15	1	x	1	0	No	No
16	1	x	1	1	Yes	No
SEAT SWITCH SEQUENCE TABLE (NO SRO ENABLED)						
1	Seat	Direction	FS1		Yes	No
2	Seat	FS1	Direction		Yes	No
3	Direction	Seat	FS1		No	Seat Fault
4	Direction	FS1	Seat		No	Seat Fault
5	FS1	Seat	Direction		No	Seat Fault
6	FS1	Direction	Seat		No	Seat Fault

SRO (Static Return to Off) TRUTH TABLE						
	Direction Sw.	FS1 Sw.			Drive	Fault Indicated
1	0	0			No	None
2	0	1			No	None
3	1	0			No	None
4	1	1			Yes	None
SRO (Static Return to Off) SEQUENCE TABLE						
1	Direction	FS1			Yes	None
2	FS1	Direction within 2 seconds			Yes	None
3	FS1	Direction after 2 seconds			No	SRO FAULT

Accelerator Characteristics

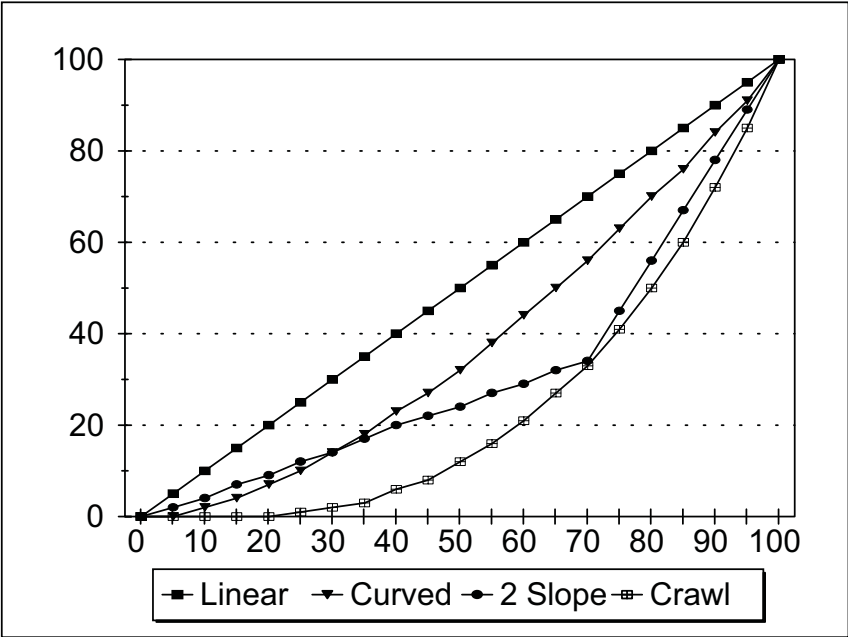

Thermal Cutback Characteristic

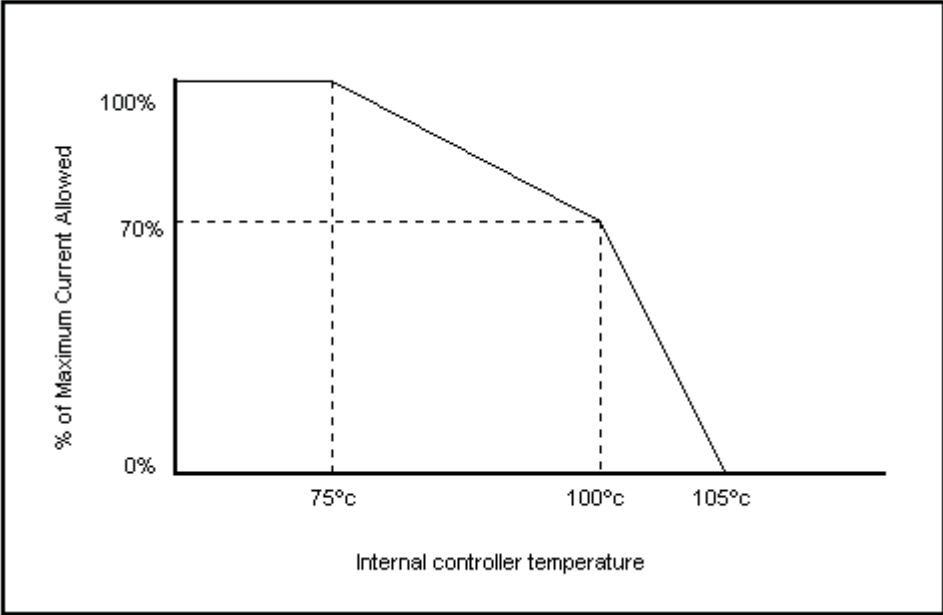

Safe Operating Area Graphs

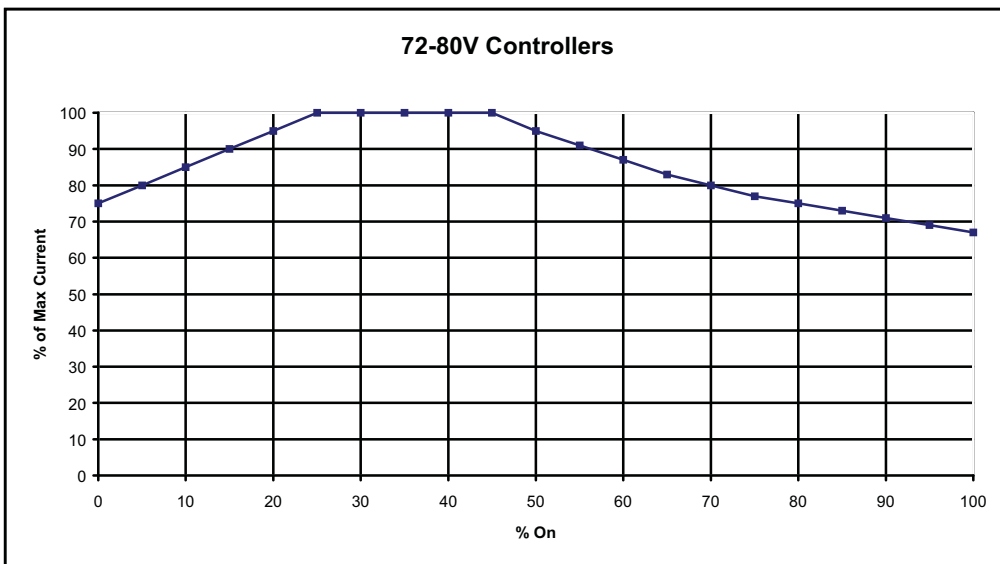
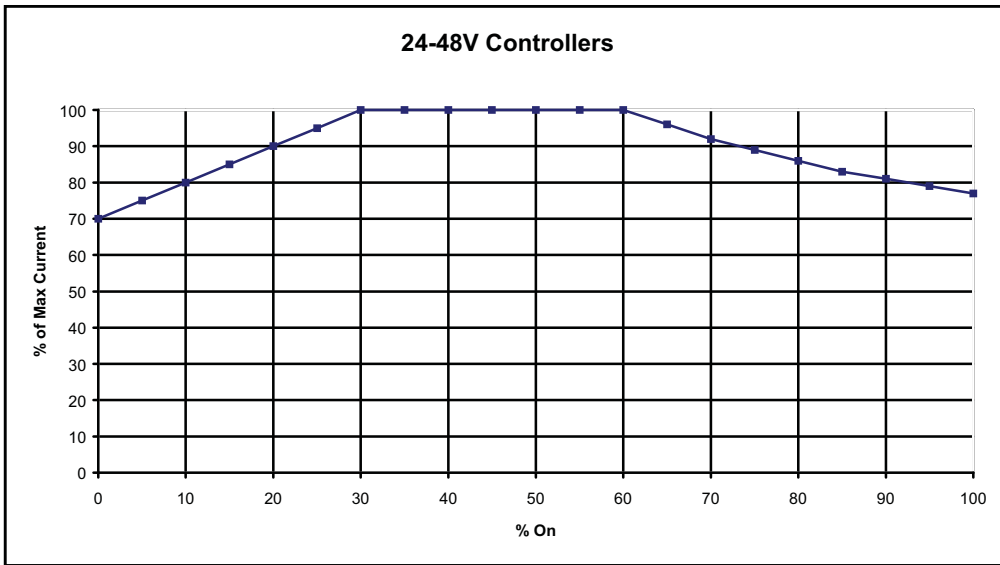

Figure 1 Light Wiring - Low I/O Logic. (Pump Functions in brackets.)

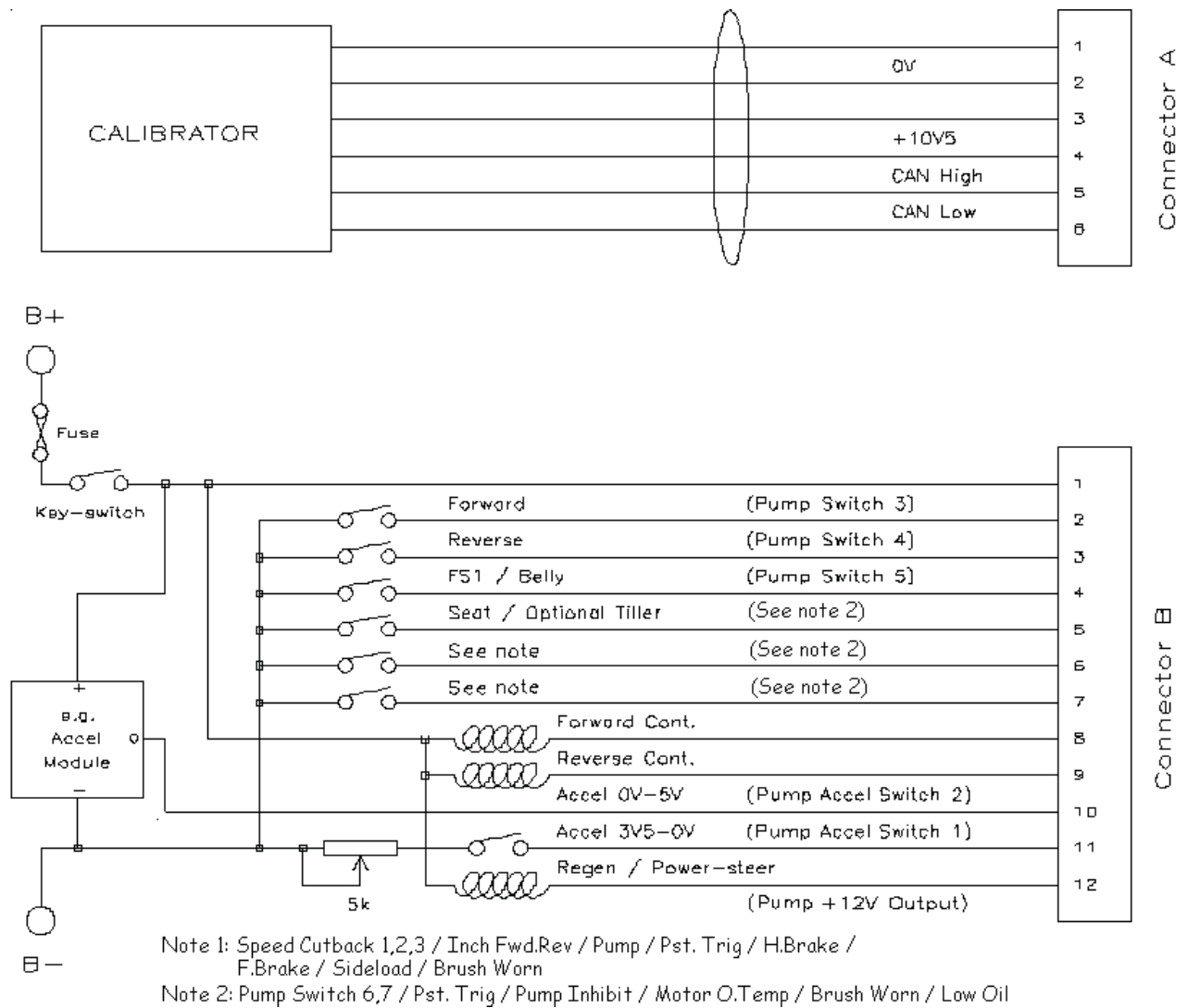

Figure 2 Light Wiring - Medium I/O Logic

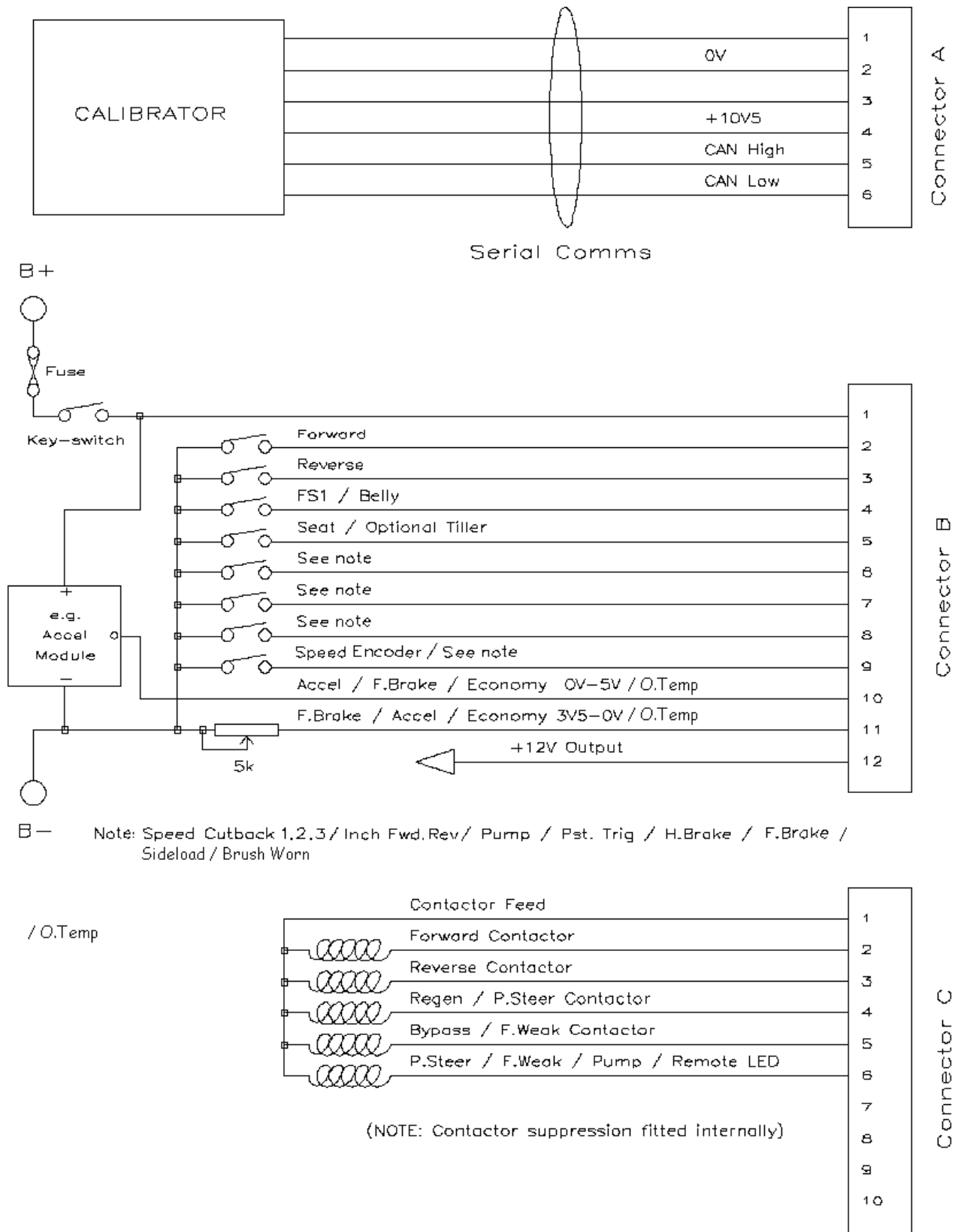
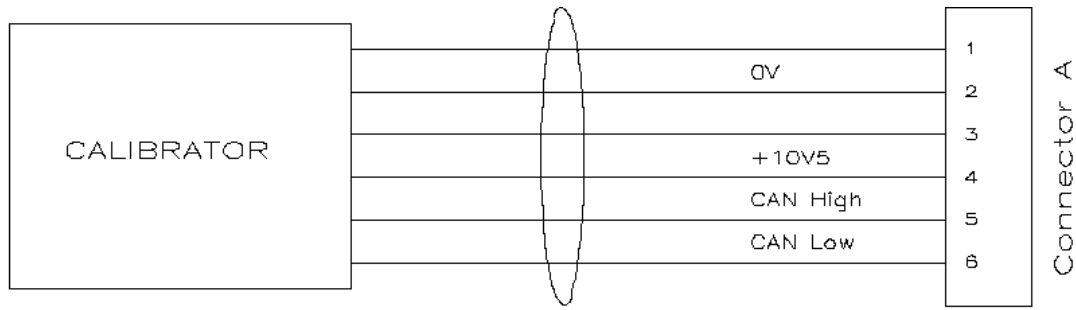
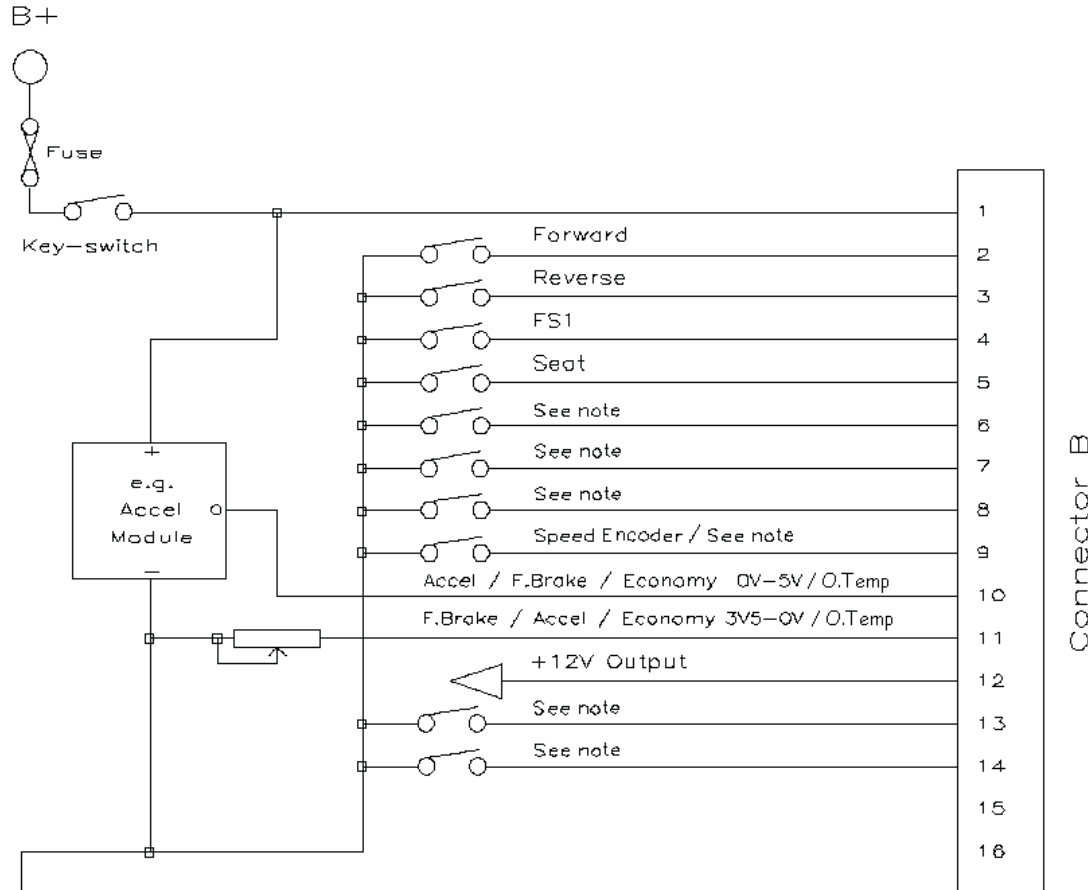

Figure 3 Light Wiring - High I/O Logic



Serial Comms



Note: Speed Cutback 1,2,3 / Inch Fwd,Rev / Pump / Pst. Trig / H.Brake / F.Brake / Sideload / Brush Warn

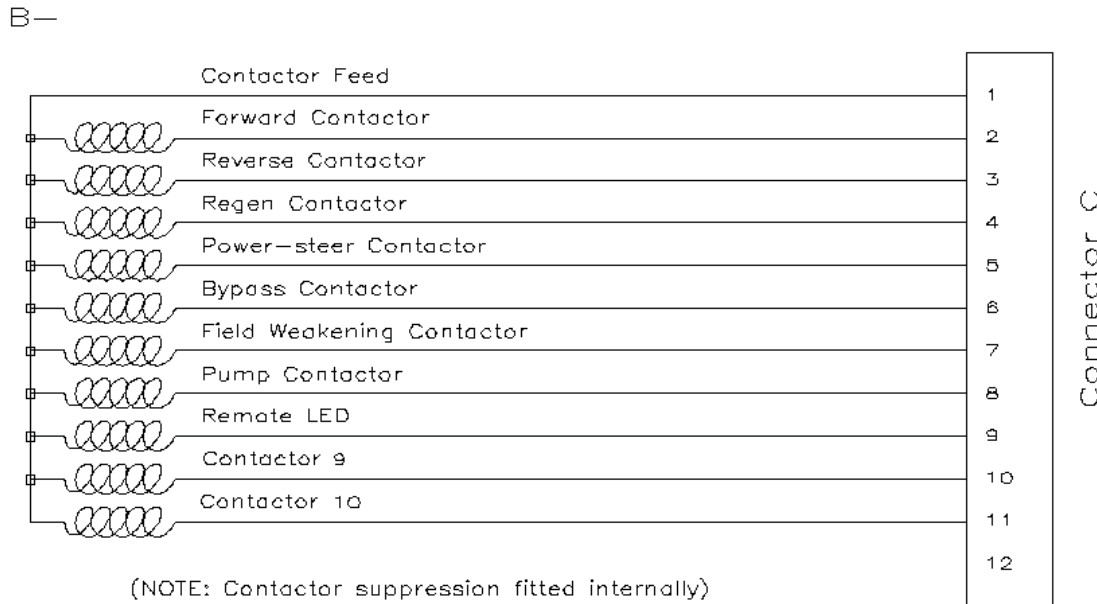

(NOTE: Contactor suppression fitted internally)

Figure 4 Series Traction Regen

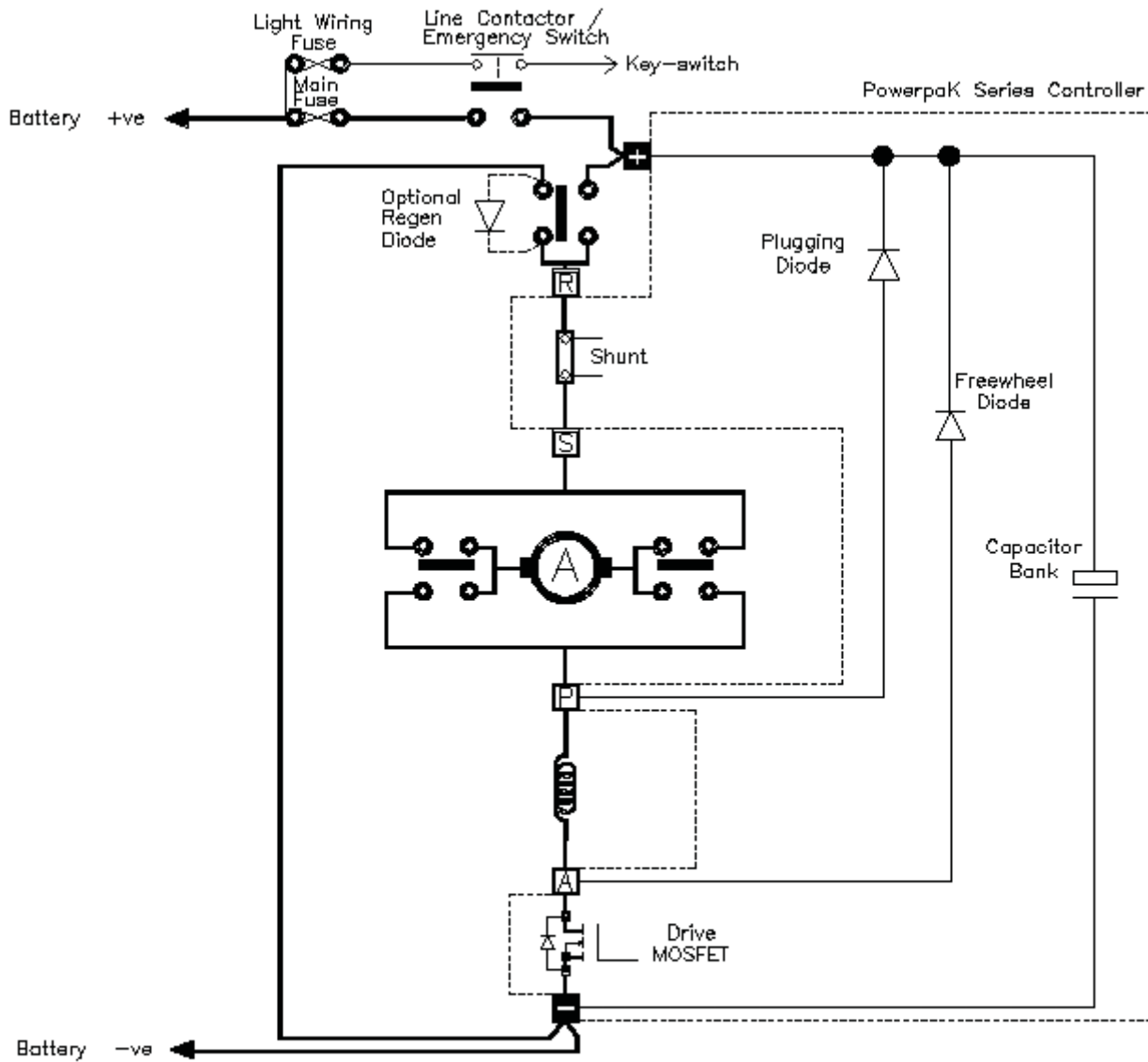

Note: When an emergency battery disconnect switch is fitted, the key switch must be fed through an auxiliary switch to prevent overvoltage damage due to disconnection during regen.

Figure 5 Series Traction Plugging

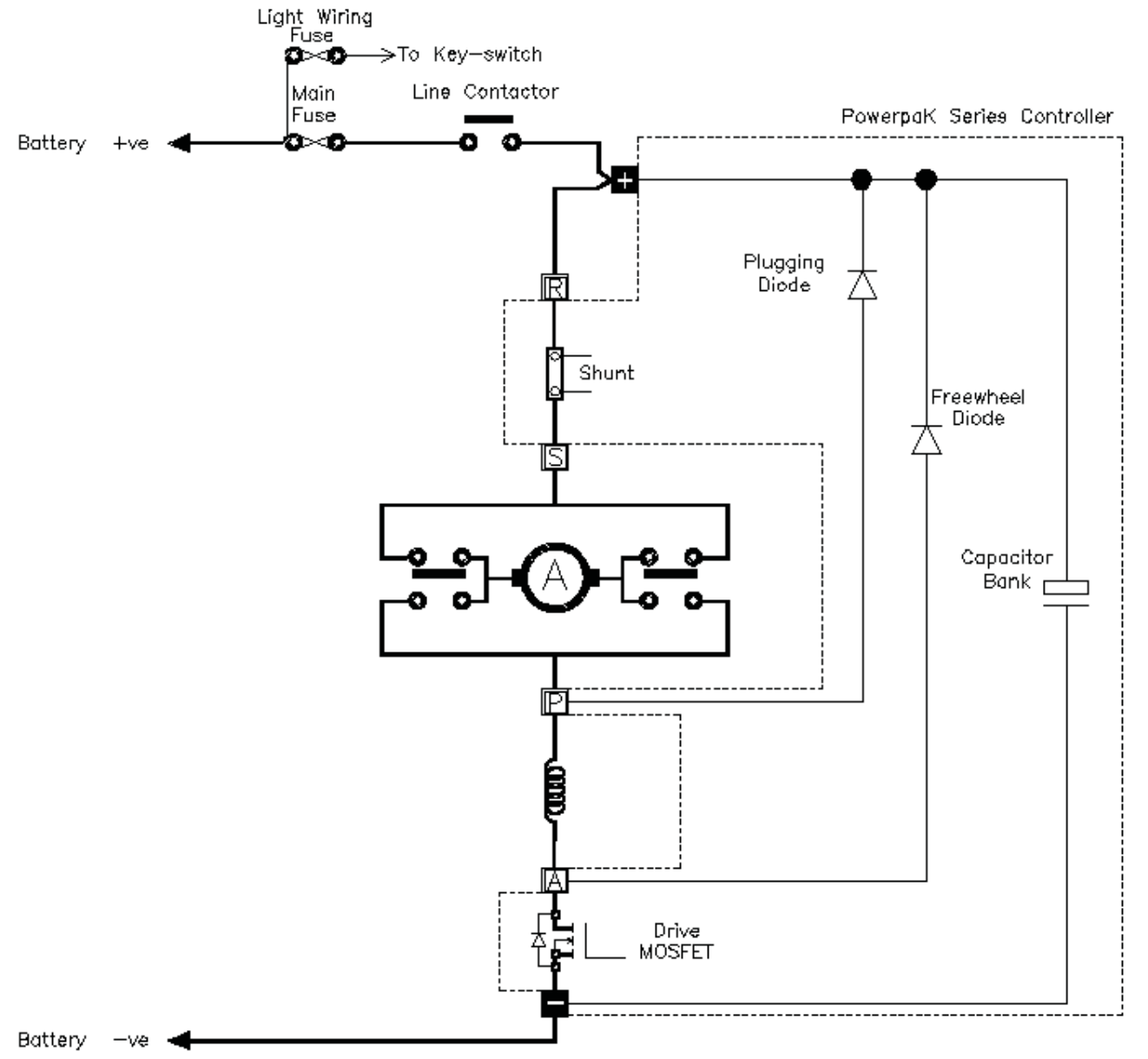

Figure 6 Series Pump

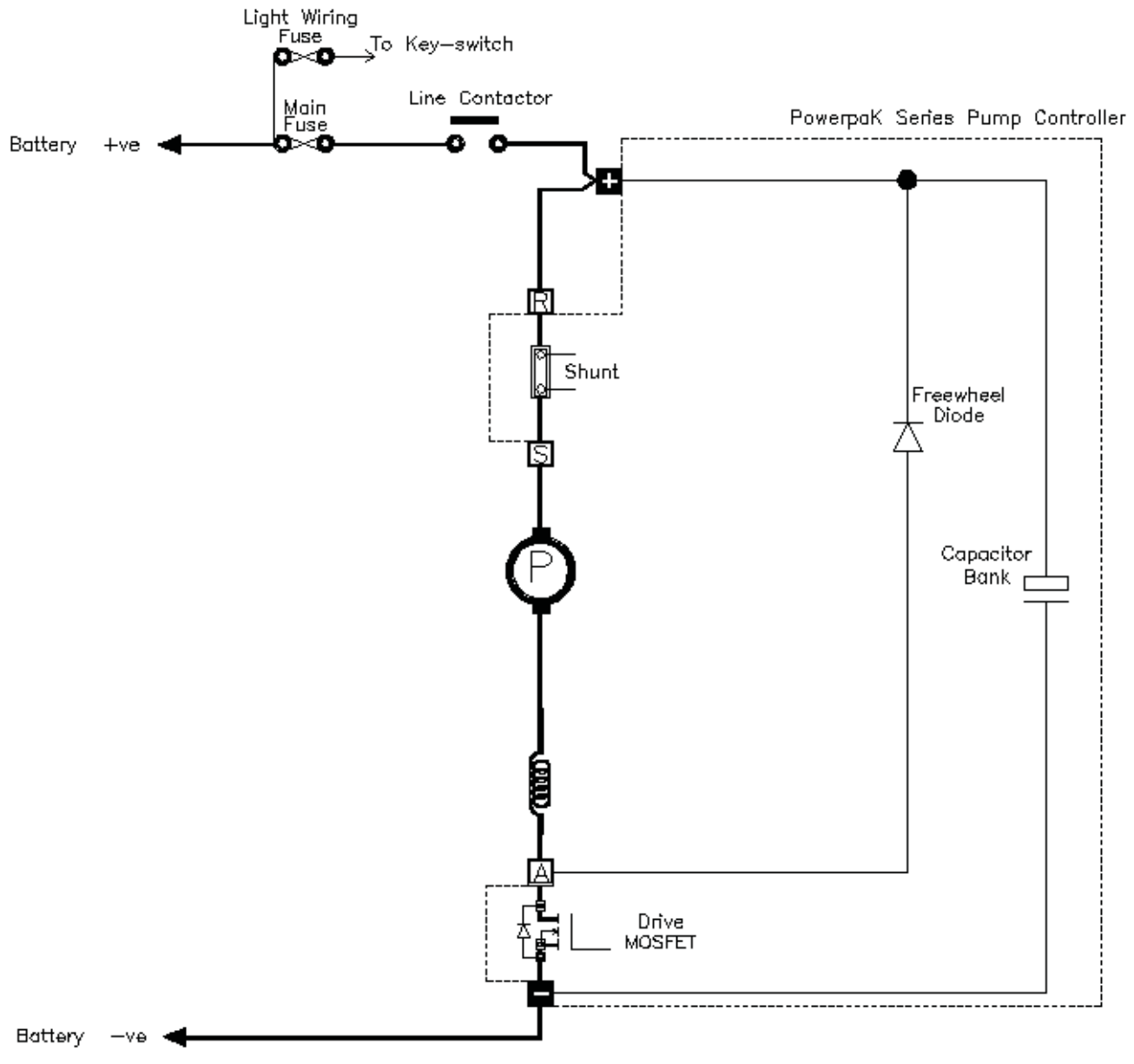
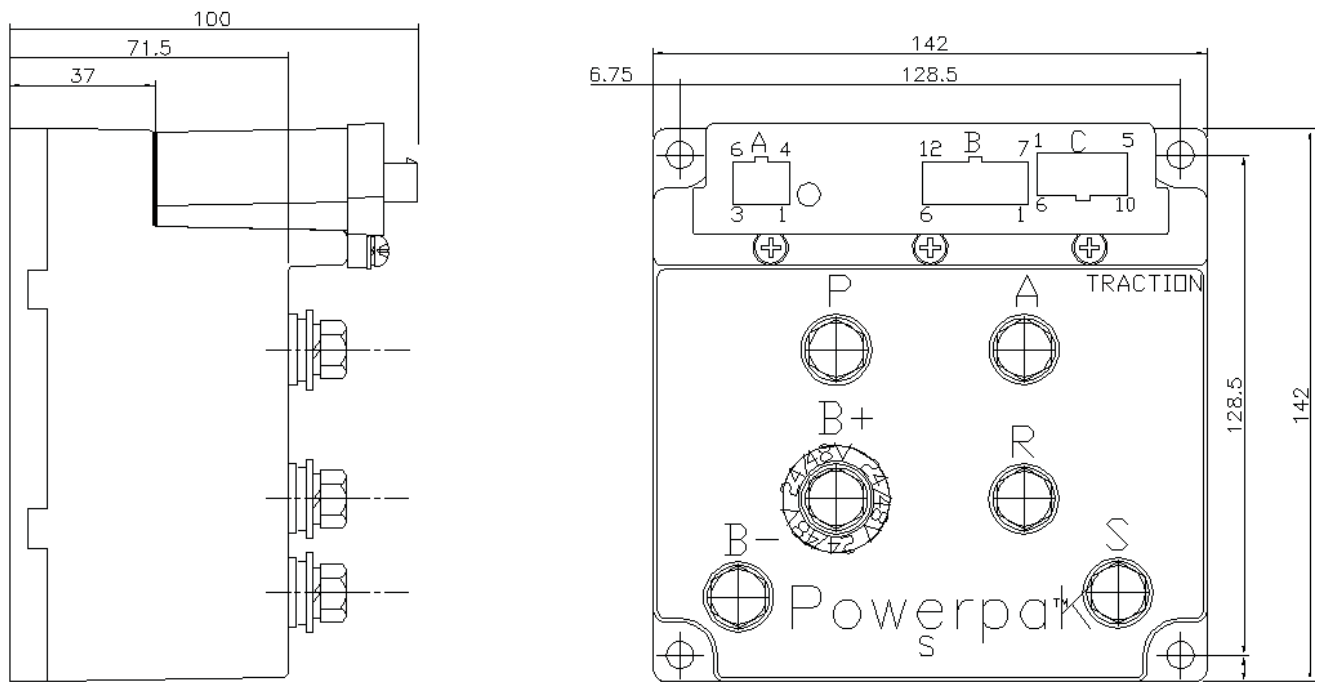

Figure 7 Mechanical Details



NB: Diagram shows controller with Medium I/O Logic fitted
Mounting holes are for M6 bolts.



Section F: Controller (Accelerator Parameters)

The following is a step by step set of instructions for setting the accelerator parameters for the Sevcon PowerPak.

Note: Before setting any parameters, the potentiometer needs to be centered.

1. Using the calibrator, go into the Traction Test Section. (Section 1.3)
2. Scroll over to 1.3.2. (This reading is the Accelerator voltage that the controller is currently reading from the handle accelerator with the handle switch in the neutral position)
3. Write this Voltage down. (This is the Accelerator Zero Voltage)
4. Rotate the handle grips completely forward or reverse. (The voltage should go down)
5. Write this voltage down. (This is the Accelerator Full Voltage)
6. After recording these two voltages, use the **DOWN** arrow and you will be toggled over to the Traction Personalities Accelerator Zero Level. 1.2.28
7. Using the Accelerator Full Voltage you wrote down earlier, set the voltage on 1.1.28 to .04 volts below that number.

Example: If the voltage read on 1.3.2 was 3.26 volts than the voltage setting on 1.1.28 would be 3.22 volts. Scroll over to 1.1.29 Accelerator Full Level and set the voltage .04 volts above the voltage that was recorded earlier.

Example: If the voltage went down to 0, you would set the voltage to .04 volts.

Note: After completing these steps, push the down arrow and you will be toggled back to 1.3.2. Scroll over to 1.3.1 Accelerator % and check the operation of the accelerator. When in the neutral position it should read 0%. When the grips are rotated this number should climb up to 100%.